

1977

# Modeling a thermal power plant drum-type boiler for control: a parameter identification approach

Chin Chen

*Iowa State University*

Follow this and additional works at: <https://lib.dr.iastate.edu/rtd>

 Part of the [Oil, Gas, and Energy Commons](#), and the [Systems Engineering Commons](#)

## Recommended Citation

Chen, Chin, "Modeling a thermal power plant drum-type boiler for control: a parameter identification approach " (1977). *Retrospective Theses and Dissertations*. 7599.

<https://lib.dr.iastate.edu/rtd/7599>

This Dissertation is brought to you for free and open access by the Iowa State University Capstones, Theses and Dissertations at Iowa State University Digital Repository. It has been accepted for inclusion in Retrospective Theses and Dissertations by an authorized administrator of Iowa State University Digital Repository. For more information, please contact [digirep@iastate.edu](mailto:digirep@iastate.edu).

## INFORMATION TO USERS

This material was produced from a microfilm copy of the original document. While the most advanced technological means to photograph and reproduce this document have been used, the quality is heavily dependent upon the quality of the original submitted.

The following explanation of techniques is provided to help you understand markings or patterns which may appear on this reproduction.

1. The sign or "target" for pages apparently lacking from the document photographed is "Missing Page(s)". If it was possible to obtain the missing page(s) or section, they are spliced into the film along with adjacent pages. This may have necessitated cutting thru an image and duplicating adjacent pages to insure you complete continuity.
2. When an image on the film is obliterated with a large round black mark, it is an indication that the photographer suspected that the copy may have moved during exposure and thus cause a blurred image. You will find a good image of the page in the adjacent frame.
3. When a map, drawing or chart, etc., was part of the material being photographed the photographer followed a definite method in "sectioning" the material. It is customary to begin photoing at the upper left hand corner of a large sheet and to continue photoing from left to right in equal sections with a small overlap. If necessary, sectioning is continued again — beginning below the first row and continuing on until complete.
4. The majority of users indicate that the textual content is of greatest value, however, a somewhat higher quality reproduction could be made from "photographs" if essential to the understanding of the dissertation. Silver prints of "photographs" may be ordered at additional charge by writing the Order Department, giving the catalog number, title, author and specific pages you wish reproduced.
5. PLEASE NOTE: Some pages may have indistinct print. Filmed as received.

**University Microfilms International**  
300 North Zeeb Road  
Ann Arbor, Michigan 48106 USA  
St. John's Road, Tyler's Green  
High Wycombe, Bucks, England HP10 8HR

## INFORMATION TO USERS

This material was produced from a microfilm copy of the original document. While the most advanced technological means to photograph and reproduce this document have been used, the quality is heavily dependent upon the quality of the original submitted.

The following explanation of techniques is provided to help you understand markings or patterns which may appear on this reproduction.

1. The sign or "target" for pages apparently lacking from the document photographed is "Missing Page(s)". If it was possible to obtain the missing page(s) or section, they are spliced into the film along with adjacent pages. This may have necessitated cutting thru an image and duplicating adjacent pages to insure you complete continuity.
2. When an image on the film is obliterated with a large round black mark, it is an indication that the photographer suspected that the copy may have moved during exposure and thus cause a blurred image. You will find a good image of the page in the adjacent frame.
3. When a map, drawing or chart, etc., was part of the material being photographed the photographer followed a definite method in "sectioning" the material. It is customary to begin photoing at the upper left hand corner of a large sheet and to continue photoing from left to right in equal sections with a small overlap. If necessary, sectioning is continued again – beginning below the first row and continuing on until complete.
4. The majority of users indicate that the textual content is of greatest value, however, a somewhat higher quality reproduction could be made from "photographs" if essential to the understanding of the dissertation. Silver prints of "photographs" may be ordered at additional charge by writing the Order Department, giving the catalog number, title, author and specific pages you wish reproduced.
5. PLEASE NOTE: Some pages may have indistinct print. Filmed as received.

### University Microfilms International

300 North Zeeb Road  
Ann Arbor, Michigan 48106 USA  
St. John's Road, Tyler's Green  
High Wycombe, Bucks, England HP10 8HR

77-29,828

CHEN, Chin, 1940-  
MODELING A THERMAL POWER PLANT DRUM-TYPE BOILER  
FOR CONTROL: A PARAMETER IDENTIFICATION APPROACH.

Iowa State University, Ph.D., 1977  
Engineering, systems science

**Xerox University Microfilms**, Ann Arbor, Michigan 48106

Modeling a thermal power plant  
drum-type boiler for control:  
A parameter identification approach

by

Chin Chen

A Dissertation Submitted to the  
Graduate Faculty in Partial Fulfillment of  
The Requirements for the Degree of  
DOCTOR OF PHILOSOPHY

Major: Electrical Engineering

Approved:

Signature was redacted for privacy.

In Charge of Major/~~Work~~

Signature was redacted for privacy.

For/~~the~~ Major/Department

Signature was redacted for privacy.

For the Graduate College

Iowa State University  
Ames, Iowa

1977

## TABLE OF CONTENTS

	<u>Page</u>
I. INTRODUCTION	1
A. General Statement	1
B. Modeling Approaches for a Boiler	2
1. Physical approach	2
2. Black-box approach	10
3. The modeling approach in this research	12
II. BOILER PROCESSES	14
A. Gas Path Equations	17
B. Transfer of Heat From Flue Gas to the Waterwall	20
C. Transfer of Heat From Flue Gas to Superheater	21
D. Transfer of Heat Through Metal Tube Wall	27
E. Heat Transfer Between Inner Most Layers of Metal Tube and Working Fluid Inside the Tube	31
F. Variation of Drum Pressure	34
G. Superheater Equations	37
H. Flow of Superheated Steam Through Throttle Valves	39
III. BOILER MODEL	41
A. Model Equations	43
B. Boiler Model in Frequency Domain	47
C. A Simplified Boiler Model	58
IV. DATA MEASUREMENT	66
V. CONCLUSIONS	71
VI. LITERATURE CITED	73
VII. ACKNOWLEDGMENTS	76

VIII.	APPENDIX A.	TRANSFER FUNCTION FOR WATERWALL TUBE WALL DIVIDED INTO THREE LAYERS	77
IX.	APPENDIX B.	TRANSFER FUNCTION FOR A SUPERHEATER TUBE WALL DIVIDED INTO THREE LAYERS	81
X.	APPENDIX C.	REDUCTION OF TRANSFER FUNCTION BLOCKS	84

## I. INTRODUCTION

### A. General Statement

The principal functions of a power system are to convert energy from various forms to electric energy and to transmit this energy to consumers in diversified areas. The smooth flow of energy to all parts of a power system is a fundamental requirement. To satisfy this requirement, it is desirable that the power generation units be properly controlled so that the production and consumption of energy can be maintained in equilibrium at all times.

At the present time, the majority of the electric power generation units are thermal power plants. Although these plants are subject to frequent adjustments in response to load variations, the control of thermal power plants has not always been adequate (4); the control of the power plant boilers is generally accomplished by a number of independent analog or direct digital control (DDC) devices designed on a single-input and single-output basis. When an error is detected from a certain variable, the corresponding control device starts to act. This will cause error to other variables, and the other related control devices start to act. The control devices will adjust to each other until the disturbances subside. This kind of control is very slow and ineffective. For a multiple-input and multiple-output system, it is desirable to have multivariable control to produce fast and effective control action under specified criteria.

In this research a model for a thermal power plant boiler of forced circulation is developed. The model is intended for use in multivariable control studies on boilers for the following purposes:



- a) for automated control of steam power generation, and
- b) to minimize fluctuations in boiler pressure and temperature caused by load changes and control actions.

### B. Modeling Approaches for a Boiler

A boiler unit is a distributed system involving mainly fluid flow and heat transfer processes. The fluid flow path of the boiler in connection with the turbine is shown in Fig. 1. The field equations describing these physical processes are generally in the form of nonlinear partial differential equations. Because of the complexity in boiler geometries and existence of heat capacitances which cause thermal delays, the physical phenomena in a boiler are further complicated. It is very difficult to represent the field equations for boiler system dynamics and to obtain solutions or to simulate them on computers. Some alternative modeling approaches have been considered by different boiler model investigators.

#### 1. Physical approach

One method is to make some simplifying assumptions on the physical processes so that the process can be described by lumped equations. The heat transfer processes are represented by empirical equations. The equation coefficients are then determined from the physical data of the boiler.

The resultant model equations will include nonlinear differential equations and nonlinear algebraic equations. Since it is very difficult to design control systems for nonlinear systems, these equations are usually linearized with respect to steady-state operating points. After the mathematical linearization the boiler dynamics are then represented by a

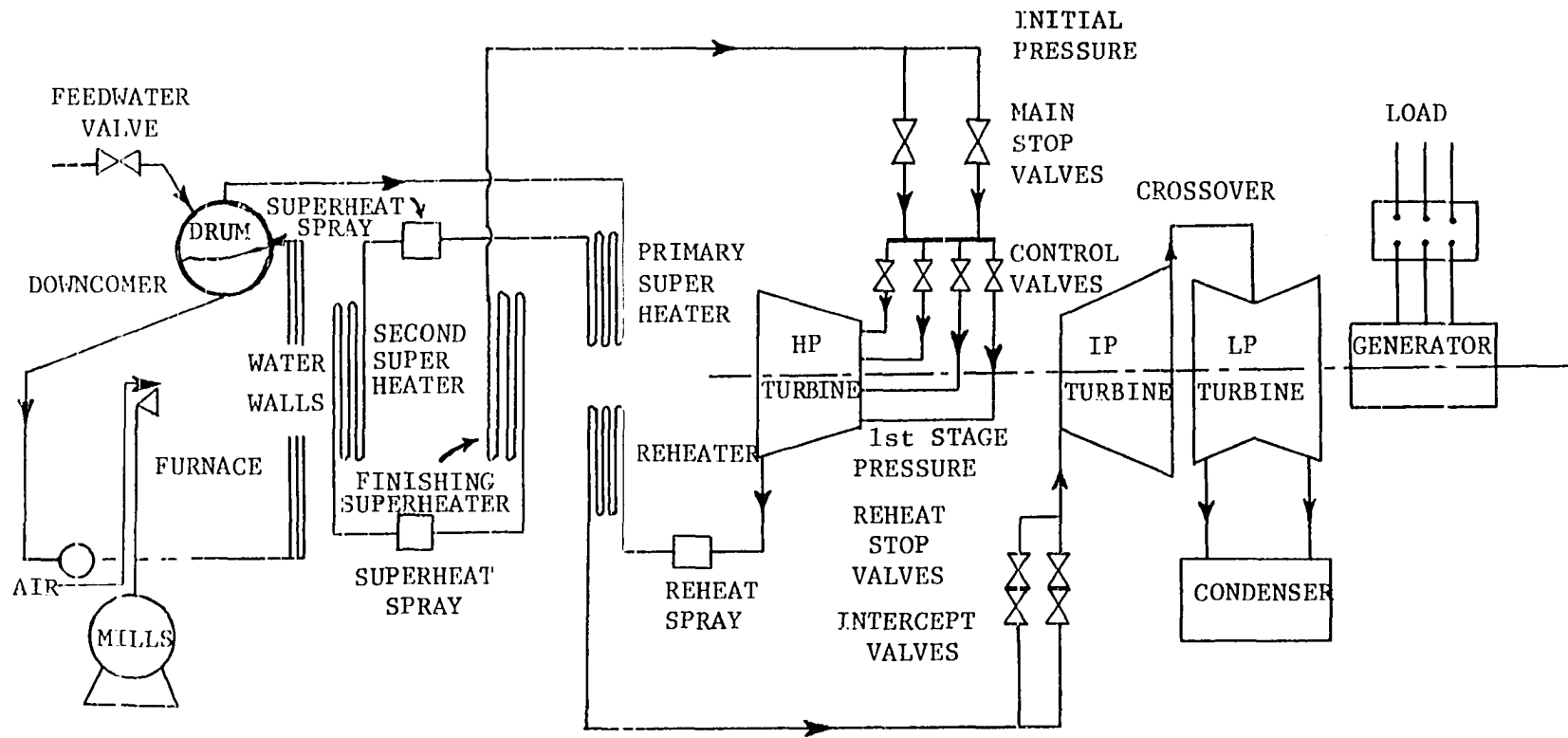

Fig. 1. Fluid-flow path for a typical drum-type boiler and single reheat turbine.

set of linear differential equations and linear algebraic equations. The model constants are generally computed from boiler design data and experimentally tested boiler operating constants.

Chien, Ergin, Ling, and Lee (5) studied the dynamics of a boiler and described analytically the development of a linear dynamic model for a boiler with this approach. This paper is the first publication which gives a comprehensive analysis of a boiler system. The boiler considered was a drum-type, oil fired naval unit with natural circulation. The boiler was divided into four sections in the analysis:

- 1) superheater,
- 2) downcomer-riser loop,
- 3) drum, and
- 4) gas path.

The important simplifying assumptions made on the boiler processes in the development of the model equations are the following (3):

- a) vapor and liquid velocities in the upriser are identical,
- b) heat-transfer rate to boiling liquid from the waterwall tube is proportional to the cube of the temperature difference between the wall and the liquid-vapor mixture (empirical equation),
- c) quality is constant throughout the upriser,
- d) temperature of liquid-vapor mixture in the upriser is always the same as the saturation temperature corresponding to drum pressure,
- e) downcomer liquid temperature is the same as the drum liquid temperature,

- f) there is no temperature gradient in the vapor phase in the drum and the temperature is always the saturation temperature corresponding to drum pressure,
- g) liquid phase in the drum has no temperature gradient except through a very thin layer at the liquid surface,
- h) evaporation or condensation rate in the drum is proportional to the difference of liquid and saturation temperatures,
- i) liquid-level changes due to bubble formation in the drum are neglected,
- j) the effect of the economizer on the overall system dynamics is neglected, and the feedwater temperature is assumed constant,
- k) the air-fuel ratio is assumed constant,
- l) in each tube bank the heat-transfer rate is determined by the tube-wall temperature and the average gas temperature (empirical equation),
- m) inertia of the hot gas is neglected, and
- n) delays of gas temperature changes due to the heat capacitance of the hot gas are neglected.

The boiler model given in this paper was considered too simple and not accurate (19). However, the analysis and modeling approach has been followed by many later boiler model investigators. In efforts for improvements of model accuracy, variations exist in the following areas for the boiler models proposed by different investigators:

- a) the simplifying assumptions on physical processes,
- b) the choice of empirical heat transfer equations,

- c) the definition of model variables, and
- d) the method of obtaining model coefficients.

It should be noticed that the following factors have been considered most significant causes of inaccuracy in a linear boiler model developed with this kind of approach:

- a) Empirical heat transfer equations represent only the overall effect of heat transfer but do not explain the actual mechanism; these equations may not be accurate when the temperature variation through the heat transfer section is large.
- b) The simplifying assumptions for the boiler processes may be inadequate in describing the processes.
- c) As temperature distributions on heat transfer surfaces are not uniform, there are problems of how to obtain accurate model coefficients.
- d) The incremental equations are accurate only for the steady-states or their neighborhood where the model coefficients are calculated. In practical boiler operation, it is difficult to maintain the boiler variables at steady-state values for a longer period when there is no adequate multivariable control on the boiler. Therefore, the boiler may not always operate under the conditions where the model constants are calculated.
- e) The steady-state operating point constants of a boiler are difficult to measure for the same reason mentioned in (d). The error on the measurement can be large.

Some other linear boiler models have been given by Daniels, Enns and Hottenstine (7), and Kwan and Anderson (15). The boiler considered by Daniels was the same one considered by Thompson at a later time. It was a drum-type, coal-fired unit with forced circulation. The use of the average of end point values of variables such as temperature, flow rates, density for each heat transfer section in this model can cause erroneous transient response as explained earlier by Thal-Larsen (29). The boiler considered by Kwan and Anderson was a drum-type coal-fired unit with natural circulation. The dynamics of the downcomer and economizer were included in the model. The mass balance equation, energy balance equation, momentum equation, and metal heat balance equation were given for each transfer section. The model was represented by 107 algebraic and differential equations. The model equations used by Kwan, Daniels, and Chien are similar, but the definitions of the variables are different. Chien defined the variables for each heat transfer section to be the average values of the sections, and Kwan defined them to be the values at the outlet of the sections. None of these models was treated correctly in view of the inaccurate factors mentioned before.

In order to obtain more accurate model coefficients so as to improve model accuracy, it has been suggested to divide each heat transfer section into small "elemental sections." Accurate steady-state thermal properties, such as temperature, pressure, and enthalpy, of hot gas, water, steam, or water-steam mixture are then obtained for all the boundary points of elemental sections. Since the differences of variable values between two nearby boundary points is small, the model equation coefficients and the thermal-physical properties along the heat transfer path can be determined

more accurately. The details of using this kind of technique have been explained by Thompson (30,31) and Shang (27). Thompson developed a linear model for a drum-type utility boiler, and Shang developed linear models for once-through boilers. In both cases experimental data measured from heat transfer sections for a steady-state operation level of the respective boiler were available for the determination of accurate steady-state thermal profiles. Extensive numerical computations were made in determining steady-state profiles and coefficient values with a digital computer.

The accuracy of the results is dependent upon the number of elemental sections into which a heat transfer section is divided. However, when more elemental sections are used, the number of model variables increases accordingly. The boiler model then becomes complex. To avoid having a boiler model too large in size, Shang (27) also suggested combining some elemental sections to form lumps along the heat transfer path. Fewer lumps can be used for heat transfer sections with less important storage behavior, such as the economizer, and more lumps should be used in the sections with important storage behavior, such as the superheater.

The data provided by Thompson in the comparison of experimental results of the boiler with responses of the model, where each heat transfer section was divided into five elemental sections, showed that the model responses were more accurate than those given by Daniels, but the accuracy was still not satisfactory. The data provided by Shang showed better accuracy of model responses. However, the limited comparison data available were not enough to justify the model accuracy. In both cases, the models do not satisfy the requirement of simplicity for control design purposes.

Several persons, including Kwatny et al. (16), McDonald (18), McDonald and Kwatny (19), and McDonald et al. (20), have studied nonlinear models for a boiler-turbine unit, expecting that a nonlinear model could cover a wider range of boiler loads. The boiler was the same one considered by Daniel et al. (7) and Thompson (30). Since a nonlinear model is complex itself, care was taken to keep the model in its simplest possible form. The model given by Kwatny, McDonald, and Spare (16) was actually the same model given by McDonald and Kwatny (19). Some process equations used in the model do not adequately represent the actual processes, especially those representing the transfer of heat through the waterwall tubes and into the drum. There is a major heat transfer delay in the transfer of heat through the tube walls and into the drum system, and the effect of these processes on the dynamic performance of the boiler is significant. McDonald (18) proposed a nonlinear boiler model at a later time where the effect of tube wall metal on heat transfer was considered, but the model was still not well-defined.

There are many difficulties involved in the determination of a nonlinear model to be valid for wider boiler operation ranges. The obvious ones among them are the following:

- a) The empirical heat transfer equations may not be valid for a wide range of state variations because these equations are determined from the observations of steady-state heat transfer.
- b) Model coefficients become functions of the boiler states, and relations among them are hard to determine.



## 2. Black-box approach

Another method of modeling a physical system is called the "black-box method." The dynamic performance of a physical system is observed from its output response with respect to several input signals. Then the possible model transfer functions which match the input-output relations are investigated. The determination of model transfer functions generally requires intuition, knowledge in systems theory, and experience with the thermal system. The feature of modeling with this approach is that only the overall system behavior is required for the model, and it usually leads to simple mathematical form.

Since the model is developed based on the dynamic response of the system, it can describe the system dynamics very well if the model is correct. However, since the transfer function which can fit one set of input-output data is not unique, frequently a model for a complex multivariable system is derived which accurately fits one set of input-output data but is inaccurate for a different set. This is particularly true for systems involving nonlinear processes.

Some black-box models for thermal power plant boilers have been proposed, e.g. by Profos (23), de Mello and Imad (8), Laubli and Fenton (17) and de Mello, Mills and B'rells (9). They have been included and discussed in a recent publication by Anderson (1).

One common problem with a black-box model is how to find the model constants. In earlier days, it was suggested to simulate the model on an analog computer and to find the model constants by tuning the potentiometers on the analog computer and comparing the response of the model with

the response of the physical system for step inputs or ramp inputs. This approach is time consuming and difficult to obtain accurate results, especially for a multivariable system. With the progress in system identification, the parameter identification technique becomes available for providing a convenient means of estimating model constants. The input-output data measured from the physical system with inputs perturbed are required for the identification computation. The computations are performed on a digital computer. The input-output data should be measured from the test on the physical system with inputs perturbed. This kind of measurement is usually easier to do than measuring the steady-state operation point values as required for computations with models developed with the physical approach.

Applications of the parameter identification technique to identify parameters for some thermal and nuclear power plant models have been reported (10,12,21,22,24,25). Among them Park (22) and Eklund and Gustavsson (10) identified thermal power plant boiler models. The identification by Eklund and Gustavsson was based on single input experiments, and that by Park was based on multiple input experiments. The boiler model identified by Park was very close to that proposed by Laubli and Fenton (17). The model inputs are fuel flow rate and control valve position, and the model outputs are throttle pressure and steam flow rate. The measured dynamic response data from a utility fossil power plant boiler were used to compute the model parameter constants. The results showed that the outputs of a model with constants computed with a set of dynamic data agree very well with the measured outputs for a period of about twenty to thirty

minutes. However, the model with parameters computed with one set of data could not produce comparable output responses for a different set of physical data measured at nearly the same power level.

### 3. The modeling approach in this research

Because of the shortcomings of the boiler models developed with the previous two approaches, in which a model developed with physical approach is too complex for control studies and a model developed with black-box method may not represent the boiler for a longer period, a boiler model developed here will utilize the advantages available from these two approaches. The resultant model may be considered as a more accurate black-box model.

The model equations will be developed based on physical principles, and the advantageous parameter identification method can be used to compute the model constants. With model constants computed by this method, it is no longer necessary to divide the heat transfer section into elemental sections. Thus the resultant model will have the complexity at most that of the simplest physical model. Since the model constants can be computed with the dynamic response data of the boiler, the model will be able to describe the boiler dynamics very well.

In order to obtain an accurate model suitable for control studies, all the system processes which have significant effects to the overall system behavior will be included. Unlike all the black-box models given before in which the temperature features of a boiler are not included, the model developed here will include important pressure features as well as

temperature features. Temperature features are important for boiler controls, as will be explained later.

The model variables, such as temperature, pressure, and mass flow rate for each boiler component will be defined to be the "effective average values" of the corresponding properties. The physical equations which are nonlinear will be linearized with respect to steady-state operation points. Although this will result in a model which is accurate only around these operation points, the model can be accurate for a wide load range of the boiler when the temperatures across the heat transfer sections and the drum pressure are maintained to have minimum deviation from the desired operation points during load changes with suitable multivariable control. This scheme is possible because the rate of heat transfer is a function of temperature gradient and medium mass flow rate. When the temperature gradient is fixed, the rate of heat transfer becomes a function of mass flow rate. The heat transfer equations then become closer to linear and valid for a wider range of linear perturbations.

Care should be taken in measuring the dynamic physical data for identification computation. The boiler must operate under desired steady-state operation conditions for a period before the inputs are perturbed and the data are recorded.

## II. BOILER PROCESSES

The boiler is constructed mainly of metal tubes and a drum. The burning of fuel produces heat in the furnace which is essentially surrounded by waterwall tubes. The hot gas is drafted by fans. Waterwall tubes, superheater tubes, reheater tubes, economizer, and air heater are located in a gas passage and absorb heat from the hot gas. The fraction of heat which is not absorbed is lost to the air through the stack. Figure 2 shows the diagram of the gas flow path.

Inside the different boiler sections, flows water, steam, or a mixture of both. The saturated water at drum pressure enters the downcomer at the downcomer inlets located at the bottom of the drum. While circulating through the waterwall tubes, the water absorbs heat and is converted partially into steam. The mixture of steam and water discharges into the drum at the waterwall outlets located at the upper portion of the drum, where the water and the steam are separated. When part of the water in the drum system is converted into steam, the water level in the drum decreases at the same time. A feedwater control is used to feed water out of the economizer into the drum so that the water level in the drum can be maintained. The steam in the drum leaves the drum and passes through superheaters before going through the throttle valves. The steam gains additional energy in the superheaters and becomes superheated at the throttle valve. The steam with high heat energy potential is then discharged through the throttle valve into the turbine in which part of the heat energy is converted into mechanical energy that drives the turbine. The steam and water flow paths are shown in Fig. 3.

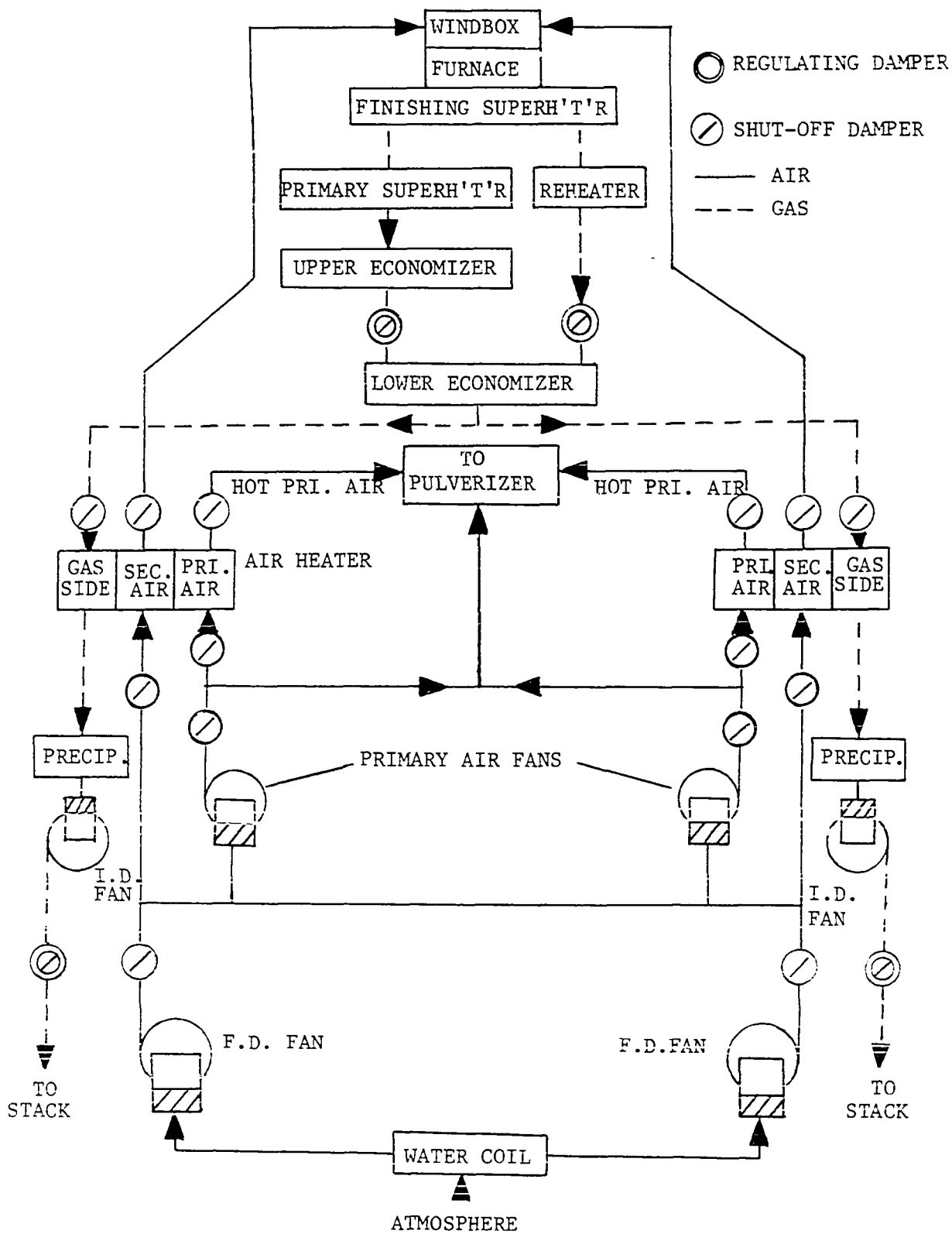

Fig. 2. Air and gas flow.

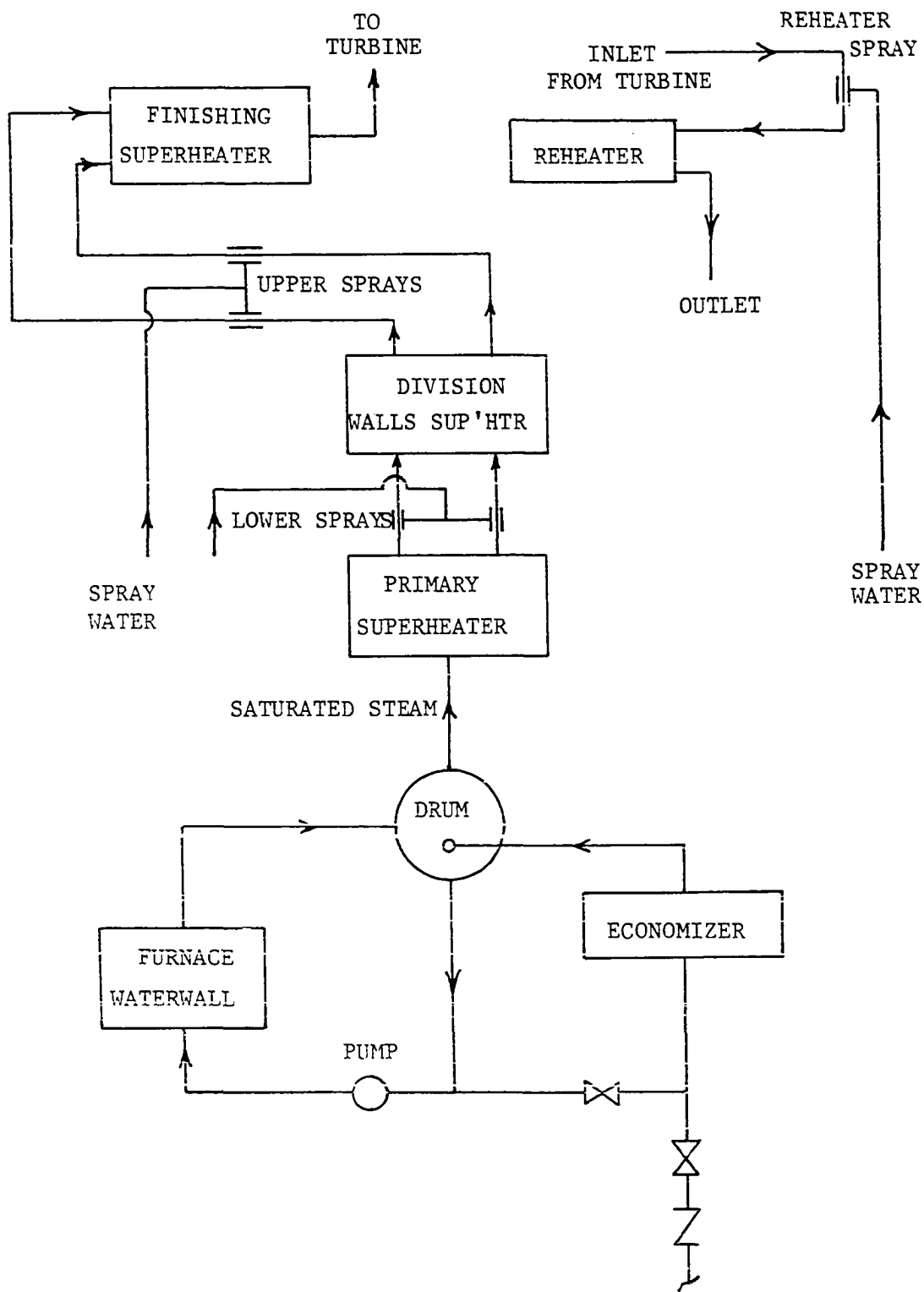

Fig. 3. Steam and water flow.

In the model development, the "effective average" values of process variables are used to describe the processes they represent. Thus the variables in the model are defined to be the effective average values of the corresponding process variables. Since the dynamics of the economizer are negligible for the overall boiler dynamic performance, the economizer will not be included in the model.

#### A. Gas Path Equations

Time constants for gas dynamics are so short in comparison to the steam-water side (6) that the dynamics of the flue gas can be ignored.

The heat produced in the combustion is determined by

$$q = K_f W_f + C_f W_f T_{fl} + C_a W_a T_a - C_{ash} W_{ash} T_{ash} \quad (2-A1)$$

heat produced      heat carried      heat carried      heat lost  
 by fuel burning      by fuel      by air      with ash

The mass rate of flue gas production is

$$W_g = W_f + W_a - W_{ash} \quad (2-A2)$$

The heat produced in the furnace is absorbed by different boiler sections or lost to the air. An equation which describes the balance of energy of hot gas is

$$q = q_{gw} + q_p + q_s + q_f + q_{ge} + q_{gr} \quad (2-A3)$$

where

- $q_{gw}$  = rate of heat transfer from gas to waterwall
- $q_p$  = rate of heat transfer to primary superheater
- $q_s$  = rate of heat transfer to secondary superheater
- $q_f$  = rate of heat transfer to finishing superheater



$q_{gr}$  = flow of heat into reheater section

$q_{ge}$  = flow of heat into economizer section

$K_f$  = caloric value of fuel

$C_f$  = specific heat of fuel

$C_a$  = specific heat of air

$C_{ash}$  = specific heat of ash

$W_f$  = fuel flow rate

$W_a$  = air flow rate

$W_{ash}$  = rate of ash formation

$T_{f1}$  = temperature of the fuel flowing into furnace

$T_a$  = temperature of the air flowing into furnace

$T_{ash}$  = ash temperature

and

$$q_{gr} = K_g W_g T_{gr} \quad (2-A4)$$

$$q_{ge} = (1 - K_g) W_g T_{ge} \quad (2-A5)$$

where

$K_g$  = the fraction of gas which flows into reheater section

$T_{gr}$  = temperature of the gas flowing into reheater section

$T_{ge}$  = temperature of the gas flowing into economizer section

$W_g$  = flow rate of the hot gas.

Defining

$$q_{sh} = q_p + q_s + q_f$$

$$q_{re} = q_{gr} + q_{ge}$$

and let  $q_n$  be the rate of heat flowing out of the furnace. The heat input and output relation in the gas path is then

$$q_n = q - q_{gw}$$

$$q_{re} = q_n - q_{sh}$$

The incremental equations for these two equations are

$$\Delta q_n = \Delta q - \Delta q_{gw} \quad \text{and} \quad (2-A6)$$

$$\Delta q_{re} = \Delta q_n - \Delta q_{sh} \quad . \quad (2-A7)$$

The incremental equations for Eqs. (2-A4) and (2-A5) are

$$\frac{\Delta q_{gr}}{q_{gro}} = \frac{\Delta W_g}{W_{go}} + \frac{\Delta T_{gr}}{T_{gro}} \quad \text{and} \quad (2-A8)$$

$$\frac{\Delta q_{ge}}{q_{geo}} = \frac{\Delta W_g}{W_{go}} + \frac{\Delta T_{ge}}{T_{geo}} \quad . \quad (2-A9)$$

For complete fuel burning in combustion, the average fraction of ash produced from fuel is determined by the chemical property of the fuel. The average ratio of ash production rate and flow rate is a constant. Let

$$R_{hf} = \frac{W_{ash}}{W_f} \quad .$$

Equation (2-A2) becomes

$$W_g = (1 - R_{hf})W_f + W_a \quad (2-A10)$$

The incremental equation is simply

$$\Delta W_g = (1 - R_{hf})\Delta W_f + \Delta W_a \quad (2-A11)$$

Also, Eq. (2-A1) becomes

$$q = (K_f + C_{f1}T_{f1} - C_{ash}T_{ash}R_{hf})W_f + C_a T_a W_a \quad (2-A12)$$

The incremental equation for this equation is

$$\Delta q = K \Delta W_f + C_a T_a \Delta W_a \quad (2-A13)$$

where

$$K = K_f + C_f T_{fl} - C_{ash} T_{ash} R_{hf} \quad .$$

The temperature of flue gas in the furnace is estimated by

$$T_f = \frac{q}{C_g W_g} \quad .$$

The incremental form of this equation is

$$\Delta T_f = \frac{T_{fo}}{q_o} \Delta q - \frac{T_{fo}}{W_{go}} \Delta W_g \quad . \quad (2-A14)$$

#### B. Transfer of Heat From Flue Gas to the Waterwall

Transfer of heat to the waterwall tubes involves a radiation process and a convection process. Since the convection heat transfer contributes only about six to seven percent of the total heat transfer to the waterwall tubes (28), the average heat transfer may be described by a radiation process only.

The radiant heat is absorbed by the tube wall in accordance with the Stefan-Boltzman Law:

$$q_{gw} = \sigma e A_f (T_f^4 - T_1^4) \quad (2-B1)$$

where

$T_f$  = flame temperature

$T_1$  = effective average tube wall temperature

$e$  = emissivity factor, depending on the tube material and surface condition

$\sigma$  = Stefan-Boltzman constant,  $1.73 \times 10^{-9}$  Btu/ft<sup>2</sup>Hr<sup>o</sup>R<sup>4</sup>

$A_f$  = effective flame envelope area

$q_{gw}$  = rate of heat transfer to waterwall

The incremental equation for (2-B1) is

$$\frac{\Delta q_{gw}}{q_{gwo}} = \frac{4T_{fo}^3}{T_{fo}^4 - T_{lo}^4} \Delta T_f - \frac{4T_{lo}^3}{T_{fo}^4 - T_{lo}^4} \Delta T_l \quad (2-B2)$$

### C. Transfer of Heat From Flue Gas to Superheater

The flow of gas through the superheaters is in the following sequence

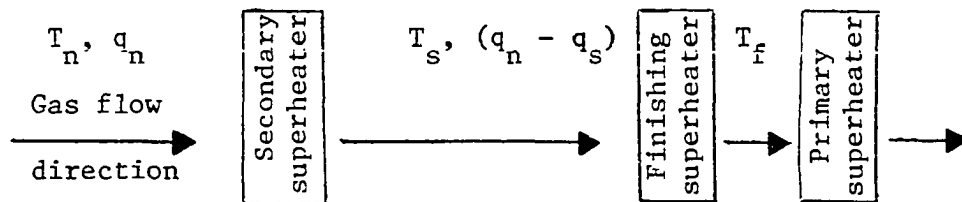

where the secondary superheater is also called a partial division wall superheater. The finishing superheater is also called a pendant superheater, and the primary superheater is also called a convection superheater.

The temperature of the flue gas leaving the furnace is given by

$$T_n = \frac{q - q_{gw}}{C_g W_g} \quad (2-C1)$$

The transfer of heat to the secondary superheater is by both radiation and convection.

$$q_s = q_{sr} + q_{sc} \quad (2-C2)$$

The rate of radiation heat transfer is given by

$$q_{sr} = \sigma e_{l1} A_{l1} (T_n^4 - T_{ms}^4) \quad (2-C3)$$

The rate of convection heat transfer is given by

$$q_{sc} = K_1 W_g^n (T_n - T_{ms}) \quad (2-C4)$$

where

$T_{ms}$  = effective average temperature of secondary superheater tube wall surface

$W_g$  = flue gas flow rate

$C_g$  = specific heat of flow gas

The temperature of the flue gas leaving the secondary superheater is given by

$$T_s = T_n - \frac{q_s}{C_g W_g} \quad (2-C5)$$

The transfer of heat to the finishing superheater is also by radiation and convection. The corresponding equations are

$$q_f = q_{fr} + q_{fc} \quad (2-C6)$$

$$q_{fr} = \sigma e_2 A_2 (T_s^4 - T_{mf}^4) \quad (2-C7)$$

$$q_{fc} = K_2 W_g^n (T_s - T_{mf}) \quad (2-C8)$$

The transfer of heat to the primary superheater is mainly by convection. The temperature of the flue gas leaving the finishing superheater is given by

$$T_p = T_s - \frac{q_f}{C_g K_g W_g} \quad (2-C9)$$

where

$K_g$  = the fraction of flue gas flowing into primary superheater section

The heat transferred to the tube wall is

$$q_p = K_3 (K_g W_g)^n (T_p - T_{mp}) \quad (2-C10)$$

The temperature of the gas flowing into the economizer section is given by

$$T_{ge} = T_p - \frac{q_p}{C_g K_g W_g}$$

The temperature of the flue gas flowing into the reheater section is

$$T_{gr} = T_p$$

and the fraction of gas which flows into the reheater section is

$$W_{re} = (1 - K_g) W_g .$$

The total heat flowing into the reheater section and the economizer section is

$$q_{re} = q_{gr} + q_{ge} = K_g W_g T_{gp} + (1 - K_g) W_g T_{ge}$$

where the variables have already been defined in Section A for Eqs. (2-A4) and (2-A5).

The incremental equations for the above equations are

$$\frac{\Delta T_n}{T_{no}} = \frac{1}{q_o - q_{gwo}} \Delta q - \frac{1}{q_o - q_{gwo}} \Delta q_{gw} - \frac{\Delta W_g}{W_{go}} \quad (2-C1a)$$

$$\Delta q_s = \Delta q_{sr} + \Delta q_{sc} \quad (2-C2a)$$

$$\frac{\Delta q_{sr}}{q_{sro}} = \frac{4T_{no}^3}{T_{no}^4 - T_{mso}^4} \Delta T_n - \frac{4T_{mso}^3}{T_{no}^4 - T_{mso}^4} \Delta T_{ms} \quad (2-C3a)$$

$$\frac{\Delta q_{sc}}{q_{sco}} = \frac{1}{T_{no} - T_{mso}} \Delta T_n - \frac{1}{T_{no} - T_{mso}} \Delta T_{ms} + \frac{n}{W_{go}} \Delta W_g \quad (2-C4a)$$

$$\Delta T_s = \Delta T_n - \frac{T_{no} - T_{so}}{q_{so}} \Delta q_s + \frac{T_{no} - T_{so}}{W_{go}} \Delta W_g \quad (2-C5a)$$

$$\Delta q_f = \Delta q_{fr} + \Delta q_{fc} \quad (2-C6a)$$

$$\frac{\Delta q_{fr}}{q_{fro}} = \frac{4T_{so}^3}{T_{so}^4 - T_{mfo}^4} \Delta T_s - \frac{4T_{mfo}^3}{T_{so}^4 - T_{mfo}^4} \Delta T_{mf} \quad (2-C7a)$$

$$\frac{\Delta q_{fc}}{q_{fco}} = \frac{1}{T_{so} - T_{mfo}} \Delta T_s - \frac{1}{T_{so} - T_{mfo}} \Delta T_{mf} + \frac{n}{W_{go}} \Delta W_g \quad (2-C8a)$$

$$\Delta T_q = \Delta T_s - \frac{T_{so} - T_{po}}{q_{fo}} \Delta q_f + \frac{T_{so} - T_{po}}{W_{go}} \Delta W_g \quad (2-C9a)$$

$$\frac{\Delta q_p}{q_{po}} = \frac{1}{T_{po} - T_{mpo}} \Delta T_p - \frac{1}{T_{po} - T_{mpo}} \Delta T_{mp} + \frac{n}{W_{go}} \Delta W_g \quad (2-C10a)$$

Combining Eqs. (2-C2a), (2-C3a), and (2-C4a),

$$\begin{aligned} \Delta q_s = & \left( \frac{4q_{sro} T_{no}^3}{T_{no}^4 - T_{mso}^4} + \frac{q_{sco}}{T_{no} - T_{mso}} \right) \Delta T_n \\ & - \left( \frac{4q_{sro} T_{mso}^3}{T_{no}^4 - T_{mso}^4} + \frac{q_{sco}}{T_{no} - T_{mso}} \right) \Delta T_{ms} + \frac{nq_{sco}}{W_{go}} \Delta W_g \end{aligned} \quad (2-C11)$$

Combining Eqs. (2-C6a), (2-C7a), and (2-C8a),

$$\begin{aligned} \Delta q_f = & \left( \frac{4q_{fro} T_{so}^3}{T_{so}^4 - T_{mfo}^4} + \frac{q_{fco}}{T_{so} - T_{mfo}} \right) \Delta T_s \\ & - \left( \frac{4q_{fro} T_{mfo}^3}{T_{so}^4 - T_{mfo}^4} + \frac{q_{fco}}{T_{so} - T_{mfo}} \right) \Delta T_{mf} + \frac{nq_{fco}}{W_{go}} \Delta W_g \end{aligned} \quad (2-C12)$$

Substituting Eq. (2-C1a) into Eq. (2-C5a),

$$\Delta T_s = \frac{T_{no}}{q_o - q_{gwo}} \Delta q - \frac{T_{no}}{q_o - q_{gwo}} \Delta q_{gw} - \frac{T_{no} - T_{so}}{q_{so}} \Delta q_s - \frac{T_{so}}{W_{go}} \Delta W_g \quad (2-C13)$$

Substituting Eq. (2-C13) into Eq. (2-C9a),

$$\begin{aligned} \Delta T_p = & \frac{T_{no}}{q_o - q_{wo}} \Delta q - \frac{T_{no}}{q_o - q_{gwo}} \Delta q_{gw} - \frac{T_{no} - T_{so}}{q_{so}} \Delta q_s \\ & - \frac{T_{so} - T_{po}}{q_{fo}} \Delta q_f - \frac{T_{po}}{W_{go}} \Delta W_g \end{aligned} \quad (2-C14)$$

Substituting Eq. (2-C14) into Eq. (2-C11),

$$\Delta q_s = K_1 (\Delta q - \Delta q_{gw}) - K_2 \Delta T_{ms} - K_3 \Delta W_g \quad (2-C15)$$

where

$$\begin{aligned} K_1 &= \frac{T_{no}}{q_o - q_{gwo}} \left( \frac{4q_{sro} T_{no}^3}{T_{no}^4 - T_{mso}^4} + \frac{q_{sco}}{T_{no} - T_{mso}} \right) \\ K_2 &= \frac{4q_{sro} T_{mso}}{T_{no}^4 - T_{mso}^4} + \frac{q_{sco}}{T_{no} - T_{mso}} \\ K_3 &= \frac{T_{no}}{W_{go}} \left( \frac{4q_{sro} T_{no}^3}{T_{no}^4 - T_{mso}^4} + \frac{q_{sco}}{T_{no} - T_{mso}} \right) - \frac{nq_{sco}}{W_{go}} \end{aligned}$$

Substituting Eq. (2-C5) into Eq. (2-C13),

$$\begin{aligned} \Delta T_s = & \left( \frac{T_{no}}{q_o - q_{gwo}} - K_1 \frac{T_{no} - T_{so}}{q_{so}} \right) (\Delta q - \Delta q_{gw}) \\ & + K_2 \frac{T_{no} - T_{so}}{q_{so}} \Delta T_{ms} - \left( \frac{T_{so}}{W_{go}} + K_3 \frac{T_{no} - T_{so}}{q_{so}} \right) \Delta W_g \end{aligned} \quad (2-C16)$$

Substituting Eq. (2-C16) into Eq. (2-C12),

$$\Delta q_f = K_4 (\Delta q - \Delta q_{gw}) + K_5 \Delta T_{ms} - K_6 \Delta T_{mf} - K_7 \Delta W_g \quad (2-C17)$$



where

$$K_4 = \left( \frac{4q_{fro} T_{so}^3}{T_{so}^4 - T_{mfo}^4} + \frac{q_{fco}}{T_{so} - T_{mfo}} \right) \left( \frac{T_{no}}{q_o - q_{gwo}} - K_1 \frac{T_{no} - T_{so}}{q_{so}} \right)$$

$$K_5 = K_2 \left( \frac{4q_{fro} T_{so}^3}{T_{so}^4 - T_{mfo}^4} + \frac{q_{fco}}{T_{so} - T_{mfo}} \right) \left( \frac{T_{no} - T_{so}}{q_{so}} \right)$$

$$K_6 = \frac{4q_{fro} T_{mfo}^3}{T_{so}^4 - T_{mfo}^4} + \frac{q_{fco}}{T_{so} - T_{mfo}}$$

$$K_7 = \left( \frac{4q_{fro} T_{so}^3}{T_{so}^4 - T_{mfo}^4} + \frac{q_{fco}}{T_{so} - T_{mfo}} \right) \left( \frac{T_{so}}{W_{go}} + K_3 \frac{T_{no} - T_{so}}{q_{so}} \right) - \frac{nq_{fco}}{W_{go}}$$

Substituting Eqs. (2-C15) and (2-C17) into Eq. (2-C14),

$$\begin{aligned} \Delta T_p = & \left( \frac{T_{no}}{q_o - q_{gwo}} - K_1 \frac{T_{no} - T_{so}}{q_{so}} - K_4 \frac{T_{so} - T_{po}}{q_{fo}} \right) (\Delta q - \Delta q_{gw}) \\ & + \left( K_2 \frac{T_{no} - T_{so}}{q_{so}} - K_5 \frac{T_{so} - T_{po}}{q_{fo}} \right) \Delta T_{ms} + K_6 \left( \frac{T_{so} - T_{po}}{q_{fo}} \right) \Delta T_{mf} \\ & - \left( \frac{T_{po}}{W_{go}} - K_3 \frac{T_{no} - T_{so}}{q_{so}} - K_7 \frac{T_{so} - T_{po}}{q_{fo}} \right) \Delta W_g \end{aligned} \quad (2-C18)$$

Substituting Eq. (2-C18) into Eq. (2-C10a),

$$\Delta q_p = K_8 (\Delta q - \Delta q_{gw}) + K_9 \Delta T_{ms} + K_{10} \Delta T_{mf} - K_{11} \Delta T_{mp} - K_{12} \Delta W_g \quad (2-C19)$$

where

$$K_8 = \frac{q_{po}}{T_{fo} - T_{mpo}} \left( \frac{T_{no}}{q_o - q_{gwo}} - K_1 \frac{T_{no} - T_{so}}{q_{so}} - K_4 \frac{T_{so} - T_{po}}{q_{fo}} \right)$$

$$K_9 = \frac{q_{po}}{T_{po} - T_{mpo}} \left( K_2 \frac{T_{no} - T_{so}}{q_{so}} - K_5 \frac{T_{so} - T_{po}}{q_{fo}} \right)$$

$$K_{10} = \frac{K_6 q_{po}}{T_p - T_{mpo}} \left( \frac{T_{so} - T_{po}}{q_{fo}} \right)$$

$$K_{11} = \frac{q_{po}}{T_{po} - T_{mpo}}$$

$$K_{12} = \frac{q_{pc}}{T_{po} - T_{mpo}} \left( \frac{T_{pc}}{W_{go}} - K_3 \frac{T_{nc} - T_{sc}}{q_{so}} - K_7 \frac{T_{sc} - T_{pc}}{q_{fo}} \right)$$

The total heat absorption in the superheater sections is

$$q_{sh} = q_s + q_f + q_p$$

Or, in incremental form

$$\Delta q_{sh} = \Delta q_s + \Delta q_f + \Delta q_p \quad (2-C20)$$

Substituting Eqs. (2-C15), (2-C7), and (2-C19) into Eq. (2-C20)

$$\Delta q_{sh} = K_{14}(\Delta q - \Delta q_{gw}) - K_{15}\Delta T_{ms} - K_{16}\Delta T_{mf} - K_{11}\Delta T_{mp} - K_{17}\Delta W_g \quad (2-C21)$$

where

$$K_{14} = K_1 + K_4 + K_8$$

$$K_{15} = K_2 - K_5 - K_9$$

$$K_{16} = K_6 - K_{10}$$

$$K_{17} = K_3 + K_7 + K_{12}$$

#### D. Transfer of Heat Through Metal Tube Wall

Assume that the temperature on both the inner and outer surfaces of a metal tube are uniform. Then the transfer of heat through the tube can be approximated by the radial heat conduction. Shang (27) used thin layer approximation to represent the physical heat transfer process as the radial heat conduction, as shown in Fig. 4.

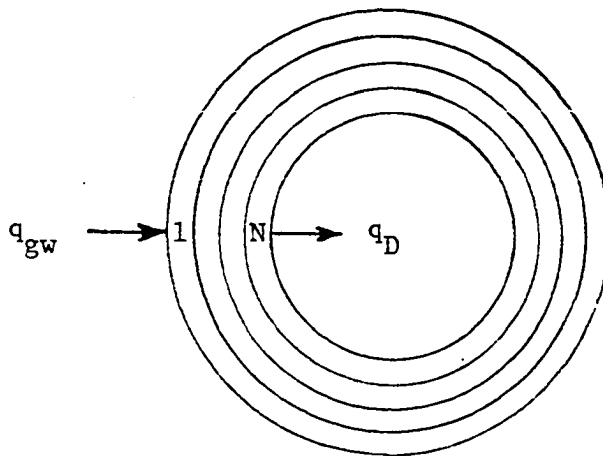

Fig. 4. A tube wall divided into thin layers.

The thin layer approximation can be used to represent a heat transfer delay through the tube wall. Suppose that the metal tube wall is composed of  $N$  thin layers so that transfer of heat in each thin layer is in the radial direction. Let

$q_i$  = rate of heat flow out from  $i$ th layer and into  $(i + 1)$ th layer.

$T_i$  = average metal temperature of each layer.

Then the variation of temperature in each layer is given by the equations

$$q_{gx} - q_1 = \rho_1 c_1 V_1 \frac{dT_1}{dt}$$

$$q_1 - q_2 = \rho_2 c_2 V_2 \frac{dT_2}{dt}$$

$$q_2 - q_3 = \rho_3 c_3 V_3 \frac{dT_3}{dt}$$

⋮  
⋮  
⋮

$$q_{N-1} - q_{Dx} = \rho_N c_N V_N \frac{dT_N}{dt} \quad (2-D1)$$

and the transfer of heat between the layers is determined by

$$\begin{aligned} q_1 &= A_1 h_1 (T_1 - T_2) \\ q_2 &= A_2 h_2 (T_2 - T_3) \\ &\vdots \\ &\vdots \\ &\vdots \\ q_{N-1} &= A_{N-1} h_{N-1} (T_{N-1} - T_N) \end{aligned} \quad (2-D2)$$

where

$A_i$  = equivalent heat transfer area of the  $i$ th layer

$$= \frac{2\pi L}{\ln \left( \frac{r_{i+1}}{r_i} \right)}$$

$r_i$  = inner radius of the  $i$ th layer

$L$  = effective tube length

$\rho_i$  = metal density of the  $i$ th layer

$c_i$  = specific heat of the  $i$ th layer

$V_i$  = volume of the  $i$ th layer

$h_i$  = heat transfer coefficient between the  $i$ th layer and the  
( $i + 1$ )th layer

$q_{gx}$  = rate of heat transfer between gas and the outer surface of  
tube of section  $x$

$q_{Dx}$  = rate of heat transfer between inner surface of the tube  
wall of the section  $x$  and the fluid inside the tube.

Combining the above two sets of equations, the state-space equations describing the temperature variations in the tube layers and obtained

$$\begin{aligned}
\frac{dT_1}{dt} &= -\frac{A_1 h_1}{\rho_1 c_1 V_1} T_1 + \frac{A_1 h_1}{\rho_1 c_1 V_1} T_2 + \frac{1}{\rho_1 c_1 V_1} q_{gx} \\
\frac{dT_2}{dt} &= \frac{A_1 h_1}{\rho_2 c_2 V_2} T_1 - \frac{(A_1 h_1 + A_2 h_2)}{\rho_2 c_2 V_2} T_2 + \frac{A_2 h_2}{\rho_2 c_2 V_2} T_3 \\
\frac{dT_3}{dt} &= \frac{A_2 h_2}{\rho_3 c_3 V_3} T_2 - \frac{(A_2 h_2 + A_3 h_3)}{\rho_3 c_3 V_3} T_3 + \frac{A_3 h_3}{\rho_3 c_3 V_3} T_4 \\
&\vdots \\
&\vdots \\
&\vdots \\
\frac{dT_{N-1}}{dt} &= \frac{A_{N-2} h_{N-2}}{\rho_{N-1} c_{N-1} V_{N-1}} T_{N-2} - \frac{(A_{N-2} h_{N-2} + A_{N-1} h_{N-1})}{\rho_{N-1} c_{N-1} V_{N-1}} T_{N-1} \\
&\quad + \frac{A_{N-1} h_{N-1}}{\rho_{N-1} c_{N-1} V_{N-1}} T_N \\
\frac{dT_N}{dt} &= \frac{A_{N-1} h_{N-1}}{\rho_N c_N V_N} T_{N-1} - \frac{A_{N-1} h_{N-1}}{\rho_N c_N V_N} T_N - \frac{1}{\rho_N c_N V_N} q_{Dx}
\end{aligned} \tag{2-D3}$$

The incremental equations for (2-D3) are

$$\begin{aligned}
\frac{d\Delta T_1}{dt} &= \frac{A_1 h_1}{\rho_1 c_1 V_1} \Delta T_1 + \frac{A_1 h_1}{\rho_1 c_1 V_1} \Delta T_2 + \frac{1}{\rho_1 c_1 V_1} \Delta q_{gx} \\
\frac{d\Delta T_2}{dt} &= \frac{A_1 h_1}{\rho_2 c_2 V_2} \Delta T_1 - \frac{(A_1 h_1 + A_2 h_2)}{\rho_2 c_2 V_2} \Delta T_2 + \frac{A_2 h_2}{\rho_2 c_2 V_2} \Delta T_3 \\
&\vdots \\
&\vdots \\
&\vdots \\
\frac{d\Delta T_{N-1}}{dt} &= \frac{A_{N-2} h_{N-2}}{\rho_{N-1} c_{N-1} V_{N-1}} \Delta T_{N-2} - \frac{(A_{N-2} h_{N-2} + A_{N-1} h_{N-1})}{\rho_{N-1} c_{N-1} V_{N-1}} \Delta T_{N-1} \\
&\quad + \frac{A_{N-1} h_{N-1}}{\rho_{N-1} c_{N-1} V_{N-1}} \Delta T_N
\end{aligned} \tag{2-D4}$$

$$\frac{d\Delta T_N}{dt} = \frac{A_{N-1} h_{N-1}}{\rho_N c_N V_N} \Delta T_{N-1} - \frac{A_{N-1} h_{N-1}}{\rho_N c_N V_N} \Delta T_N - \frac{1}{\rho_N c_N V_N} \Delta q_{Dx}$$

### E. Heat Transfer Between Inner Most Layers of Metal

#### Tube and Working Fluid Inside the Tube

For fluid flowing inside the tubes, the convective heat transfer rate may be described by

$$q_D = hA_n (T_N - T_D) \quad (2-E1)$$

with the heat transfer coefficient correlated by

$$Nu = \alpha (Re^m) (Pr)^n \quad (2-E2)$$

where

Nu = Nusselt number =  $hD/k$

Re = Reynolds number =  $UD/\mu$

Pr = Prandtl number =  $c_p \mu/k$

$\alpha, m, n$  = experimental constants

D = tube inner diameter

k = thermal conductivity of the fluid

U =  $W_D/A$  = rate of mass flow per unit cross-sectional tube area

$\mu$  = absolute viscosity

$c_p$  = specific heat of the fluid at constant pressure

$A_n$  = heat transfer surface area

$T_N$  = temperature of the inner most tube layer

$T_D$  = average bulk fluid temperature

$W_D$  = average fluid mass flow rate

Substituting Nu and Re into Eq. (2-E2) and solving for h:

$$h = \left(\frac{k}{D}\right) \alpha \left(\frac{W_D}{A} \frac{D}{\mu}\right)^m (\text{Pr})^n$$

Let

$$A_n A_D^{-m} D^{m-1} = \text{const}$$

$$\alpha k \mu^{-m} = \phi$$

then

$$h = \text{const } \phi (W_D)^m (\text{Pr})^n (A_n)^{-1}$$

and

$$q_D = \text{const } \phi (W_D)^m (\text{Pr})^n (T_N - T_D) \quad (2-E3)$$

The development above follows that given by Shang (27). The incremental equation for Eq. (2-E3) is

$$\frac{\Delta q_D}{q_{D0}} = \frac{\Delta \phi}{\phi_0} + m \frac{\Delta W_D}{W_{D0}} + n \frac{\Delta \text{Pr}}{(\text{Pr})_0} + \frac{\Delta T_N - \Delta T_D}{T_{N0} - T_{D0}} \quad (2-E4)$$

where  $\phi$  and Pr are functions of pressure and temperature and may be represented in terms of these variables.

$$\begin{aligned} \frac{\Delta q_D}{q_{D0}} &= \frac{1}{\phi_0} \left( \frac{\partial \phi}{\partial D_D} \Delta D_D + \frac{\partial \phi}{\partial T_D} \Delta T_D \right) + m \frac{\Delta W_D}{W_{D0}} \\ &+ \frac{n}{(\text{Pr})_0} \left( \frac{\partial \text{Pr}}{\partial D_D} \Delta D_D + \frac{\partial \text{Pr}}{\partial T_D} \Delta T_D \right) + \frac{\Delta T_N - \Delta T_D}{T_{N0} - T_{D0}} \\ &= \frac{m}{W_{D0}} \Delta W_D + \frac{1}{T_{N0} - T_{D0}} \Delta T_N + \left( \frac{1}{\phi_0} \frac{\partial \phi}{\partial D_D} + \frac{n}{(\text{Pr})_0} \frac{\partial \text{Pr}}{\partial D_D} \right) \Delta D_D \\ &+ \left( \frac{1}{\phi_0} \frac{\partial \phi}{\partial T_D} + \frac{n}{(\text{Pr})_0} \frac{\partial \text{Pr}}{\partial T_D} - \frac{1}{T_{N0} - T_{D0}} \right) \Delta T_D \quad (2-E4a) \end{aligned}$$

Equation (2-E3) is applicable for the superheater and the waterwall sections. For the superheater sections, Eq. (2-E4a) becomes

$$\Delta q_{Dsh} = K_{13} \Delta W_v + K_{14} \Delta T_m + K_{15} \Delta D_d - K_{16} \Delta T_{sh} \quad (2-E5)$$

where

$\Delta q_{Dsh}$  = heat absorbed by the steam in the respective superheater

$\Delta W_v$  = rate of steam flow in the respective superheater

$\Delta T_{sh}$  = temperature of steam in the respective superheater

$$K_{13} = \frac{mq_{Do}}{W_{Do}} = \frac{mq_{Dsho}}{W_{vo}} \quad \text{for respective superheater}$$

$$K_{14} = \frac{q_{Do}}{T_{No} - T_{Do}} = \frac{q_{Dsho}}{T_{mo} - T_{sho}} \quad \text{for respective superheater}$$

$$\begin{aligned} K_{15} &= \left( \frac{1}{\phi_o} \frac{\partial \phi}{\partial D_D} + \frac{n}{(Pr)_o} \frac{\partial Pr}{\partial D_D} \right) q_{Do} \\ &= \left( \frac{1}{\phi_o} \frac{\partial \phi}{\partial D_D} + \frac{n}{(Pr)_o} \frac{\partial Pr}{\partial D_D} \right) q_{sho} \quad \text{for respective superheater} \end{aligned}$$

$$\begin{aligned} K_{16} &= \left( \frac{1}{T_{No} - T_{Do}} - \frac{n}{(Pr)_o} \frac{\partial Pr}{\partial T_D} - \frac{1}{\phi_o} \frac{\partial \phi}{\partial D_D} \right) q_{Do} \\ &= \left( \frac{1}{T_{mo} - T_{sho}} - \frac{n}{(Pr)_o} \frac{\partial Pr}{\partial T_{sh}} - \frac{1}{\phi_o} \frac{\partial \phi}{\partial D_D} \right) q_{sho} \quad \text{for respective superheater} \end{aligned}$$

In the waterwall section the fluid temperature and pressure are related by Clapeyron equation

$$\frac{\Delta D_D}{\Delta T_D} = \frac{h_{fgo}}{T_{Do} v_{fgo}} \quad .$$

The rate of heat transfer to the steam-water mixture in the tube may be written as



$$\Delta q_{DW} = K_{18} \Delta W_D + K_{19} \Delta T_N - K_{20} \Delta D_D \quad (2-E6)$$

where

$$K_{18} = \frac{mq_{DWo}}{W_{Do}}$$

$$K_{19} = \frac{q_{DWo}}{T_{No} - T_{Do}}$$

$$K_{20} = \frac{T_{Do} v_{fgo}}{h_{fgo}} \left( \frac{1}{T_{No} - T_{Do}} - \frac{n}{(Pr)_o} \frac{\partial Pr}{\partial T_D} - \frac{1}{\phi_o} \frac{\partial \phi}{\partial T_D} \right) - \left( \frac{1}{\phi_o} \frac{\partial \phi}{\partial D_D} + \frac{n}{(Pr)_o} \frac{\partial Pr}{\partial D_D} \right)$$

#### F. Variation of Drum Pressure

Assume that (3)

- a) water in the drum, downcomer, and riser are saturated water at drum pressure, and
- b) steam in the drum and in the riser tube is saturated steam at drum pressure.

Let

$W_{fw}$  = feedwater flow rate,

$W_v$  = rate of steam flow out from drum,

$V_{wd}$  = volume of water in drum, downcomer, and riser,

$V_{gd}$  = volume of steam in drum, downcomer, and riser, and

$D_D$  = drum pressure,

where

$V_{wd} + V_{gd} = V$  = total internal volume of drum, downcomer, and riser.

Then the mass balance equation is

$$W_{fw} - W_v = \frac{d}{dt} (\rho_f V_{wd} + \rho_g V_{gd}) = \frac{d}{dt} [\rho_f V_{wd} + \rho_g (v - V_{wd})]$$

where

$\rho_f$  = density of the water in drum, and

$\rho_g$  = density of the steam in drum.

The incremental equation for Eq. (2-F1) is

$$\begin{aligned} \Delta W_{fw} - \Delta W_v &= \frac{d}{dt} \left[ (\rho_{fo} - \rho_{go}) \Delta V_{wd} + V_{wdo} \Delta \rho_f + V_{gdo} \Delta \rho_g \right] \\ &= (\rho_{fo} - \rho_{go}) \frac{d\Delta V_{wd}}{dt} + V_{wdo} \frac{d\Delta \rho_f}{dt} + V_{gdo} \frac{d\Delta \rho_g}{dt} \end{aligned} \quad (2-F2)$$

Since  $\rho_f$  and  $\rho_g$  are functions of drum pressure, Eq. (2-F2) may be written as

$$\Delta W_{fw} - \Delta W_v = (\rho_{fo} - \rho_{go}) \frac{d\Delta V_{wd}}{dt} + \left[ V_{wdo} \frac{\partial \rho_f}{\partial D_D} + V_{gdo} \frac{\partial \rho_g}{\partial D_D} \right] \frac{d\Delta D_D}{dt} \quad (2-F3)$$

The energy balance equation is

$$h_e \dot{W}_{fw} - h_g \dot{W}_v + \dot{Q}_{Dw} = \frac{d}{dt} (h_f \rho_f V_{wd} + h_g \rho_g V_{gd}) \quad (2-F4)$$

where

$h_e$  = enthalpy of feedwater

$h_f$  = enthalpy of water in drum

$h_g$  = enthalpy of steam in drum

The linear incremental equation for Eq. (2-F4) is

$$\begin{aligned} h_e \Delta W_{fw} &= h_{go} \Delta W_v - W_{vo} \Delta h_g + \Delta Q_{Dw} \\ &= \frac{d}{dt} [h_{fo} \rho_{fo} \Delta V_{wd} + h_{fo} V_{wdo} \Delta \rho_f + \rho_{fo} V_{wdo} \Delta h_f \\ &\quad + h_{go} \rho_{go} \Delta V_{gd} + h_{go} V_{gdo} \Delta \rho_g + V_{gdo} \rho_{go} \Delta h_g] \end{aligned} \quad (2-F5)$$

Since  $h_f$ ,  $h_g$ ,  $\rho_f$ , and  $\rho_g$  are functions of pressure in the drum, Eq. (2-F5) can be written as

$$\begin{aligned}
 & h_e \Delta W_{fw} - h_{go} \Delta W_v + \Delta q_{Dw} - W_{vo} \frac{\partial h_g}{\partial D_D} \Delta D_D \\
 &= (h_{fo} \rho_{fo} - h_{go} \rho_{go}) \frac{d\Delta V_{wd}}{dt} + \left[ h_{fo} V_{wdo} \frac{\partial \rho_f}{\partial D_D} + \rho_{fo} V_{wdo} \frac{\partial h_f}{\partial D_D} \right. \\
 &\quad \left. + h_{go} V_{gdo} \frac{\partial \rho_g}{\partial D_D} + V_{gdo} \rho_{go} \frac{\partial h_g}{\partial D_D} \right] \frac{dD_D}{dt} \quad (2-F6)
 \end{aligned}$$

where

$$\frac{dV_{gd}}{dt} = \frac{d}{dt} (V - V_{wd}) = - \frac{dV_{wd}}{dt} .$$

Let

$$a_1 = \rho_{fo} - \rho_{go}$$

$$a_2 = V_{wdo} \frac{\partial \rho_f}{\partial D_D} + V_{gdo} \frac{\partial \rho_g}{\partial D_D}$$

$$a_3 = h_{fo} \rho_{fo} - h_{go} \rho_{go}$$

$$a_4 = h_{fo} V_{wdo} \frac{\partial \rho_f}{\partial D_D} + \rho_{fo} V_{wdo} \frac{\partial h_f}{\partial D_D} + h_{go} V_{gdo} \frac{\partial \rho_g}{\partial D_D} + V_{gdo} \rho_{go} \frac{\partial h_g}{\partial D_D}$$

$$a_5 = W_{vo} \frac{\partial h_g}{\partial D_D}$$

Then Eq. (2-F3) becomes

$$a_1 \frac{d\Delta V_{wd}}{dt} + a_2 \frac{d\Delta D_D}{dt} = \Delta W_{fw} - \Delta W_v \quad (2-F7)$$

Equation (2-F6) becomes

$$a_3 \frac{d\Delta V_{wd}}{dt} + a_4 \frac{d\Delta D_D}{dt} + a_5 \Delta D_D = h_e \Delta W_{fw} - h_{go} \Delta W_v + \Delta q_{Dw} \quad (2-F8)$$

Combining Eqs. (2-F7) and (2-F8) and eliminating  $\Delta V_{wd}$ :

$$(a_1 a_4 - a_2 a_3) \frac{d\Delta D_D}{dt} + a_1 a_5 \Delta D_D = (a_1 h_e - a_3) \Delta W_{fw} - (a_1 h_{go} - a_3) \Delta W_v + a_1 \Delta q_{Dw}$$

or

$$\begin{aligned} \frac{d\Delta D_D}{dt} + \frac{a_1 a_5}{a_1 a_4 - a_2 a_3} \Delta D_D \\ = \frac{a_1 h_e - a_3}{a_1 a_4 - a_2 a_3} \Delta W_{fw} - \frac{a_1 h_{go} - a_3}{a_1 a_4 - a_2 a_3} \Delta W_v + \frac{a_1 \Delta q_{Dw}}{a_1 a_4 - a_2 a_3} \end{aligned} \quad (2-F9)$$

### G. Superheater Equations

Assume that the pressure drop across the superheater is negligible.

Then the steam pressure in the drum may be represented by the drum pressure.

The superheater equations may be written as (5,11,15)

$$W_a - W_b = V \frac{d\rho_b}{dt} \quad (2-G1)$$

$$q_{st} + W_a h_a - W_b h_b = V \frac{d}{dt} (\rho_b h_b) \quad (2-G2)$$

where

$W_a$  = rate of steam flow into the superheater section

$W_b$  = rate of steam flow out from the superheater section

$V$  = superheater volume

$\rho_b$  = steam density at superheater outlet

$h_b$  = enthalpy of steam at superheater outlet

$h_a$  = enthalpy of steam at superheater inlet

$q_{st}$  = rate of flow of heat from tube wall to steam

The incremental equation for Eq. (2-G1) is

$$\Delta W_a - \Delta W_b = v \frac{d\Delta\rho_b}{dt} \quad (2-G3)$$

The incremental equation for Eq. (2-G2) is

$$\begin{aligned} \Delta q_{st} + W_{ao} \Delta h_a + h_{ao} \Delta W_a - W_{bo} \Delta h_b - h_{bo} \Delta W_b \\ = v \left( \rho_{bo} \frac{d\Delta h_b}{dt} + h_{bo} \frac{d\Delta\rho_b}{dt} \right) \end{aligned} \quad (2-G4)$$

Combining Eqs. (2-G3) and (2-G4)

$$\begin{aligned} \Delta q_{st} + W_{ao} \Delta h_a - W_{bo} \Delta h_b - (h_{bo} - h_{ao}) \Delta W_b \\ = v \left( \rho_{bo} \frac{d\Delta h_b}{dt} + (h_{bo} - h_{ao}) \frac{d\Delta\rho_b}{dt} \right) \end{aligned} \quad (2-G5)$$

Since  $h_a$ ,  $h_b$ , and  $\rho_b$  are functions of pressure and temperature, Eq. (2-G5)

can be written as

$$\begin{aligned} \Delta q_{st} + \left( W_{ao} \frac{\partial h_a}{\partial D_D} - W_{bo} \frac{\partial h_b}{\partial D_D} \right) \Delta D_D + W_{ao} \frac{\partial h_a}{\partial T_a} \Delta T_a - W_{bo} \frac{\partial h_b}{\partial T_b} \Delta T_b \\ - (h_{bo} - h_{ao}) \Delta W_b = v \left[ \rho_{bo} \frac{\partial h_b}{\partial D_D} + (h_{bo} - h_{ao}) \frac{\partial \rho_b}{\partial D_D} \right] \frac{d\Delta D_D}{dt} \\ + \left[ v \rho_{bo} \frac{\partial h_b}{\partial T_b} + (h_{bo} - h_{ao}) \frac{\partial \rho_b}{\partial T_b} \right] \frac{d\Delta T_b}{dt} \end{aligned} \quad (2-G6)$$

Let

$$b_1 = v \left[ \rho_{bo} \frac{\partial h_b}{\partial T_b} + (h_{bo} - h_{ao}) \frac{\partial \rho_b}{\partial T_b} \right]$$

$$b_2 = W_{bo} \frac{\partial h_b}{\partial T_b}$$

$$b_3 = -v \left[ \rho_{bo} \frac{\partial h_b}{\partial D_D} + (h_{bo} - h_{ao}) \frac{\partial \rho_b}{\partial D_D} \right]$$

$$b_4 = W_{bo} \frac{\partial h_b}{\partial D_D} - W_{ao} \frac{\partial h_a}{\partial D_D}$$

$$b_5 = W_{ao} \frac{\partial h_a}{\partial T_a}$$

$$b_6 = h_{bo} - h_{ao}$$

Equation (2-G6) can be expressed as

$$b_1 \frac{d\Delta T_b}{dt} + b_2 \Delta T_b = b_3 \frac{d\Delta D_D}{dt} - b_4 \Delta D_D + b_5 \Delta T_a - b_6 \Delta W_b + \Delta q_{st} \quad (2-G7)$$

#### H. Flow of Superheated Steam Through Throttle Valves

The equation for estimating the rate of steam flow through the throttle valves has been given in many books on steam turbines (14).

$$W_T = C_T A_T \sqrt{\frac{D_T}{v_T}} \quad (2-H1)$$

where

$D_T$  = throttle pressure

$v_T$  = specific volume of the steam before throttle

$A_T$  = effective throttle area

$W_T$  = steam flow rate

$$C_T = \left[ \frac{2g\eta m}{m-1} \left( \gamma^{2/m} - \gamma^{(m+1)/m} \right) \right]^{1/2}$$

$$m = \frac{n}{n - \eta(n - 1)}$$

$\eta$  = valve efficiency

$\gamma$  = pressure ratio

$n$  = adiabatic index

For superheated steam, the ideal gas equation is observed

$$D_T v_T = RT_T$$

or

$$v_T = \frac{RT_T}{D_T} \quad (2-H2)$$

Substituting Eq. (2-H2) into (2-H1),

$$W_T = \frac{C_T}{\sqrt{R}} A_T \frac{D_T}{\sqrt{T_T}} \triangleq C_T' A_T \frac{D_T}{\sqrt{T_T}} \quad (2-H3)$$

The incremental equation for Eq. (2-H3) is

$$\frac{\Delta W_T}{W_{T0}} = \frac{\Delta A_T}{A_{T0}} + \frac{\Delta D_T}{D_{T0}} - \frac{1}{2} \frac{\Delta T_T}{T_{T0}} \quad (2-H4)$$

Another equation which predicts the steam flow rate is Napier's experimental equation

$$W_T = CA_T D_T \quad (2-H5)$$

The incremental equation for this equation is

$$\frac{\Delta W_T}{W_{T0}} = \frac{\Delta A_T}{A_{T0}} + \frac{\Delta D_T}{D_{T0}} \quad (2-H6)$$

## III. BOILER MODEL

The boiler model will be presented in the form of block diagrams in the complex frequency domain. This kind of presentation is to show the model in compact form, which provides better visualization of the relationship among the boiler variables. The boiler models developed with the black-box approach are usually presented in this form. The model developed here may be classified as a gray-box model because the model equations in the "box" are developed from physical principles.

The boiler variables which are important for control studies have been included in the model. The model has five inputs and four outputs. The inputs are

- 1) fuel flow rate,
- 2) air flow rate,
- 3) feedwater flow rate,
- 4) control valve area, and
- 5) flow rate of the circulation fluid.

The outputs are

- 1) steam flow rate,
- 2) drum pressure,
- 3) throttle steam temperature, and
- 4) the heat flow into reheater and economizer sections.

The heat flow into the reheater and the economizer sections is the heat lost from the system considered for the model. This output may not be controlled, but the physical data for this heat loss are required for parameter identification computation. The steam flow rate is the main variable



to be controlled since it determines the amount of steam energy flowing into the turbine. Drum pressure and throttle steam temperature are the most significant factors which influence the dynamic properties of a boiler. For efficient operation of a boiler, it is desirable to have these two variables controlled so that the variation of these variables are minimum during load variations.

The model has included the following boiler variables as state variables:

- a) waterwall tube metal temperature,
- b) primary superheater metal temperature,
- c) secondary superheater metal temperature,
- d) finishing superheater metal temperature,
- e) outlet steam temperature of primary superheater, and
- f) outlet steam temperature of secondary superheater.

For safe operation of a boiler, it is important to maintain these temperature values below the safety margins of the respective boiler components. The superheater outlet temperatures are usually controlled by superheater sprays. The limitation of metal temperatures may be included in the constraint functions for control studies.

In this chapter, a complete boiler model and a simplified boiler model in which the superheater sections are treated as one superheater are presented. The metal wall of the boiler is treated as one single layer. However, there is no difficulty in obtaining the transfer function with the tube wall divided into more layers; it only takes more time for mathematical manipulation. The transfer functions with the tube walls divided into

three layers are given in Appendix A and B. It is not clear what is the appropriate number of layers to be used to describe the delays of heat transfer through the tube walls. This can be determined with the results of the parameter identification computation. At the beginning, the wall may be treated as one single layer. If the heat transfer delay is not properly represented, the error between the model outputs and corresponding physical data will be large. Then the number of layers should be increased.

#### A. Model Equations

The boiler process equations have been developed in Chapter II. The equations which contribute directly to the composition of a boiler model are collected here.

##### a) Gas Path

$$\Delta q = K\Delta W_f + C_a T_a \Delta W_a \quad (2-A13)$$

$$\Delta q_n = \Delta q - \Delta q_{gw} \quad (2-A6)$$

$$\Delta q_{re} = \Delta q_n - \Delta q_{sh} \quad (2-A7)$$

$$\Delta q_{sh} = \Delta q_s + \Delta q_f + \Delta q_p \quad (2-C20)$$

$$\Delta W_g = (1 - R_{hf})\Delta W_f + \Delta W_a \quad (2-A11)$$

$$\Delta T_f = \frac{T_{fo}}{\Delta q_o} \Delta q - \frac{T_{fo}}{W_{go}} \Delta W_g \quad (2-A14)$$

$$\Delta q_{gw} = \frac{4T_{fo}^3 q_{gwo}}{T_o^4 - T_{lo}^4} \Delta T_f - \frac{4T_{lo}^3 q_{gwo}}{T_{fo}^4 - T_{lo}^4} \Delta T_l \quad (2-B2)$$

$$\Delta q_s = K_1(\Delta q - \Delta q_{gw}) - K_2\Delta T_{ms} - K_3\Delta W_g \quad (2-C15)$$

$$\Delta q_f = K_4(\Delta q - \Delta q_{gw}) + K_5\Delta T_{ms} - K_6\Delta T_{mf} - K_7\Delta W_g \quad (2-C17)$$

$$\Delta q_p = K_8(\Delta q - \Delta q_{gw}) + K_9\Delta T_{ms} + K_{10}\Delta T_{mf} - K_{11}\Delta T_{mp} - K_{12}\Delta W_g \quad (2-C19)$$

- b) The temperature of the waterwall tubes is given by Eq. (2-D4). For single layer representation of the tube wall, the variation of the metal temperature is given by

$$\frac{d\Delta T_1}{dt} = \frac{1}{\rho_w c_w V_w} (\Delta q_{gw} - \Delta q_{Dw}) \quad (3-A1)$$

- c) The rate of heat transfer to the fluid inside the waterwall tube is given by Eq. (2-E6)

$$\Delta q_{Dw} = K_{18} \Delta W_D + K_{19} \Delta T_1 - K_{20} \Delta D_D \quad (3-A2)$$

- d) The drum pressure dynamics is given by Eq. (2-F9)

$$\begin{aligned} \frac{d\Delta D_D}{dt} + \frac{a_1 a_5}{a_1 a_4 - a_2 a_3} \Delta D_D &= \frac{a_1 h_e - a_3}{a_1 a_4 - a_2 a_3} \Delta W_{fw} - \frac{a_1 h_{go} - a_3}{a_1 a_4 - a_2 a_3} \Delta W_v \\ &+ \frac{a_1 \Delta q_{gw}}{a_1 a_4 - a_2 a_3} \end{aligned} \quad (2-F9)$$

- e) The dynamics of the superheater tube metal temperature are given by Eq. (2-D4). For single layer representation of the tube wall, the variation of metal temperature of secondary superheater is given by

$$\frac{d\Delta T_{ms}}{dt} = \frac{1}{\rho_{ms} c_{ms} V_{ms}} (\Delta q_s - \Delta q_{Ds}) \quad (3-A3)$$

The variation of metal temperature of the finishing superheater is given by

$$\frac{d\Delta T_{mf}}{dt} = \frac{1}{\rho_{mf} c_{mf} V_{mf}} (\Delta q_f - \Delta q_{Df}) \quad (3-A4)$$

The variation of metal temperature of the primary superheater is given by

$$\frac{d\Delta T_{mp}}{dt} = \frac{1}{\rho_{mp} c_{mp} V_{mp}} (\Delta q_p - \Delta q_{Dp}) \quad (3-A5)$$

f) The transfer of heat to the steam in each superheater section is given by Eq. (2-E5). The equations describe the rate of heat flow to steam in the secondary superheater, finishing superheater, and primary superheater are

$$\Delta q_{Ds} = a_{11} \Delta W_s + a_{12} \Delta T_{ms} + a_{13} \Delta D_D - a_{14} \Delta T_{st} \quad (3-A6)$$

$$\Delta q_{Df} = a_{21} \Delta W_f + a_{22} \Delta T_{mf} + a_{23} \Delta D_D - a_{24} \Delta T_{ft} \quad (3-A7)$$

$$\Delta q_{Dp} = a_{31} \Delta W_p + a_{32} \Delta T_{mp} + a_{33} \Delta D_D - a_{34} \Delta T_{pt} \quad (3-A8)$$

where  $a_{ij}$  are defined as  $K_{ij}$  in Eq. (2-E5) for the respective terms. With the assumption that pressure drops through the superheaters are negligible, the steam flowing through each superheater may be approximated by

$$\Delta W_p = \Delta W_s = \Delta W_f = \Delta W_T$$

where  $W_T$  is the throttle steam flow rate.

g) The dynamics of the outlet steam temperature for each superheater section are determined by Eq. (2-G7). The equations for the respective sections are

$$b_{11} \frac{d\Delta T_{pt}}{dt} + b_{12} \Delta T_{pt} = b_{13} \frac{d\Delta D_D}{dt} - b_{14} \Delta D_D + b_{15} \Delta T_D - b_{16} \Delta W_p + \Delta q_{Dp} \quad (3-A9)$$

$$b_{21} \frac{d\Delta T_{st}}{dt} + b_{22} \Delta T_{st} = b_{23} \frac{d\Delta D_D}{dt} - b_{24} \Delta D_D + b_{25} \Delta T_{pt} - b_{26} \Delta W_s + \Delta q_{Ds} \quad (3-A10)$$

$$b_{31} \frac{d\Delta T_{ft}}{dt} + b_{32} \Delta T_{ft} = b_{33} \frac{d\Delta D_D}{dt} - b_{34} \Delta D_D + b_{35} \Delta T_{st} - b_{36} \Delta W_f + \Delta q_{Df} \quad (3-A11)$$

where  $b_{ij}$ 's are defined as  $b$ 's in Section G of Chapter II.

The intermediate variables  $\Delta q_{Dp}$ ,  $\Delta q_{Ds}$ , and  $\Delta q_{Df}$  may be eliminated:

Substituting Eq. (3-A6) into Eq. (3-A10) to obtain

$$b_{21} \frac{d\Delta T_{st}}{dt} + b_{22} \Delta T_{st} = b_{23} \frac{d\Delta D_D}{dt} - b_{24} \Delta D_D + b_{25} \Delta T_{pt} - b_{26} \Delta W_s \\ + a_{11} \Delta W_s + a_{12} \Delta T_{ms} + a_{13} \Delta D_D - a_{14} \Delta T_{st}$$

Rearranging the equation,

$$b_{21} \frac{d\Delta T_{st}}{dt} + (b_{22} + a_{14}) \Delta T_{st} = b_{23} \frac{d\Delta D_D}{dt} + (a_{13} - b_{24}) \Delta D_D \\ - (b_{26} - a_{11}) \Delta W_s + a_{12} \Delta T_{ms} + b_{25} \Delta T_{pt} \quad (3-A12)$$

Similarly, substituting Eq. (3-A7) into Eq. (3-A11),

$$b_{31} \frac{d\Delta T_{ft}}{dt} + (b_{32} + a_{24}) \Delta T_{ft} \\ = b_{33} \frac{d\Delta D_D}{dt} + (a_{23} - b_{34}) \Delta D_D - (b_{36} - a_{21}) \Delta W_f + a_{22} \Delta T_{mf} \\ + b_{35} \Delta T_{st} \quad (3-A13)$$

Substituting Eq. (3-A8) into Eq. (3-A9),

$$b_{11} \frac{d\Delta T_{pt}}{dt} + (b_{12} + a_{34}) \Delta T_{pt} = b_{13} \frac{d\Delta D_D}{dt} + (a_{33} - b_{14}) \Delta D_D \\ - (b_{16} - a_{31}) \Delta W_p + a_{32} \Delta T_{mp} + b_{15} \Delta T_D \quad (3-A14)$$

h) Equation (2-H4) will be used in the model for throttle steam flow rate:

$$\Delta W_T = \frac{W_{T0}}{A_{T0}} \Delta A_T + \frac{W_{T0}}{P_{T0}} \Delta D_T - \frac{W_{T0}}{2T_{T0}} \Delta T_T \quad (3-A15)$$

With the assumption of negligible pressure drop in the superheater sections, the following approximation can be used

$$\Delta D_D = \Delta D_T$$

$$\Delta T_T = \Delta T_{ft}$$

### B. Boiler Model in Frequency Domain

The model differential equations will be transformed to the complex-frequency domain. Then, the boiler model will be established with the transformed equations. The transformation of algebraic equations will not be performed here because they are of the same form as in time domain.

a) The dynamics of waterwall tube metal temperature is given by

Eq. (3-A1)

$$\frac{d\Delta T_1}{dt} = \frac{1}{\rho_w c_w V_w} (\Delta q_{gw} - \Delta q_{Dw}) \quad (3-A1)$$

The transformed equation is

$$\Delta T_1(s) = \frac{1}{\rho_w c_w V_w} \frac{\Delta q_{gw}(s) - \Delta q_{Dw}(s)}{s} \quad (3-B1)$$

b) Drum pressure dynamics

$$\frac{d\Delta D_D}{dt} = -P_4 \Delta D_D + P_5 \Delta W_{fw} - P_6 \Delta W_v + P_7 \Delta q_{Dw} \quad (2-F9)$$

where

$$P_4 = \frac{a_1 a_5}{a_1 a_4 - a_2 a_3}$$

$$P_5 = \frac{a_1 h_e - a_3}{a_1 a_4 - a_2 a_3}$$

$$P_6 = \frac{a_1 h_{go} - a_3}{a_1 a_4 - a_2 a_3}$$

$$P_7 = \frac{a_1}{a_1 a_4 - a_2 a_3}$$

and  $a_1$ ,  $a_2$ ,  $a_3$ ,  $a_4$ , and  $a_5$  have been defined in Section F of Chapter II. The transformed equation can be written as

$$\Delta D_D(s) = \frac{P_5 \Delta W_{fw}(s) - P_6 \Delta W_v(s) + P_7 \Delta q_{Dw}(s)}{s + P_4} \quad (3-B2)$$

c) The basic equations describing the transfer of heat through metal tubes of the superheater sections are the same. For the primary superheater

$$\frac{d\Delta T_{mp}}{dt} = \frac{1}{\rho_{mp} c_{mp} V_{mp}} (\Delta q_p - \Delta q_{Dp}) \quad (3-A5)$$

$$\Delta q_{Dp} = a_{31} \Delta W_p + a_{32} \Delta T_{mp} + a_{33} \Delta D_D - a_{34} \Delta T_{pt} \quad (3-A8)$$

Combining these two equations:

$$\frac{d\Delta T_{mp}}{dt} = P_8 \Delta q_p - P_9 \Delta D_D + P_{10} \Delta T_{pt} - P_{11} \Delta W_p - P_{12} \Delta T_{mp}$$

where

$$P_8 = \frac{1}{\rho_{mp} c_{mp} V_{mp}}$$

$$P_9 = \frac{a_{33}}{\rho_{mp} c_{mp} V_{mp}}$$

$$P_{10} = \frac{a_{34}}{\rho_{mp} c_{mp} V_{mp}}$$

$$P_{11} = \frac{a_{3i}}{\rho_{mp} c_{mp} V_{mp}}$$

$$P_{12} = \frac{a_{32}}{\rho_{mp} c_{mp} V_{mp}}$$

The transformed equation for the primary superheater metal temperature can be written as

$$\Delta T_{mp}(s) = \frac{P_8 \Delta q_p(s) - P_9 \Delta D_D(s) + P_{10} \Delta T_{pt}(s) - P_{11} \Delta W_p(s)}{s + P_{12}} \quad (3-B3)$$

For the same reason, the equations for the secondary superheater temperature and the finishing superheater temperature are Eqs. (3-B4) and (3-B5), respectively.

$$\Delta T_{ms}(s) = \frac{P_{13} \Delta q_s(s) - P_{14} \Delta D_D(s) + P_{15} \Delta T_{st}(s) - P_{16} \Delta W_s(s)}{s + P_{17}} \quad (3-B4)$$

$$\Delta T_{mf}(s) = \frac{P_{18} \Delta q_f(s) - P_{19} \Delta D_D(s) + P_{20} \Delta T_{ft}(s) - P_{21} \Delta W_f(s)}{s + P_{22}} \quad (3-B5)$$

where

$$P_{13} = \frac{1}{\rho_{ms} c_{ms} V_{ms}}$$

$$P_{14} = \frac{a_{13}}{\rho_{ms} c_{ms} V_{ms}}$$

$$P_{15} = \frac{a_{14}}{\rho_{ms} c_{ms} V_{ms}}$$

$$P_{16} = \frac{a_{11}}{\rho_{ms} c_{ms} V_{ms}}$$



$$P_{17} = \frac{a_{12}}{\rho_{ms} c_{ms} V_{ms}}$$

$$P_{18} = \frac{1}{\rho_{mf} c_{mf} V_{mf}}$$

$$P_{19} = \frac{a_{23}}{\rho_{mf} c_{mf} V_{mf}}$$

$$P_{20} = \frac{a_{24}}{\rho_{mf} c_{mf} V_{mf}}$$

$$P_{21} = \frac{a_{21}}{\rho_{mf} c_{mf} V_{mf}}$$

$$P_{22} = \frac{a_{22}}{\rho_{mf} c_{mf} V_{mf}}$$

d) The transformed equations for outlet steam temperature of the superheaters are obtained from Eqs. (3-A12), (3-A13), and (3-A14), respectively.

$$\Delta T_{st}(s) = \frac{P_{23}(s + P_{24})\Delta D_D(s) + P_{25}\Delta T_{dt} - P_{26}\Delta W_s + P_{27}\Delta T_{ms}}{s + P_{28}} \quad (3-B6)$$

$$\Delta T_{dt}(s) = \frac{P_{29}(s + P_{30})\Delta D_D(s) + P_{31}\Delta T_{st} - P_{32}\Delta W_f + P_{33}\Delta T_{mf}}{s + P_{34}} \quad (3-B7)$$

$$\Delta T_{pt}(s) = \frac{P_{35}(s + P_{36})\Delta D_D(s) + P_{37}\Delta T_D - P_{38}\Delta W_p + P_{39}\Delta T_{mp}}{s + P_{40}} \quad (3-B8)$$

where

$$P_{23} = \frac{b_{23}}{b_{21}}$$

$$P_{24} = \frac{a_{13} - b_{24}}{b_{23}}$$

$$P_{25} = \frac{b_{25}}{b_{21}}$$

$$P_{26} = \frac{b_{26} - a_{11}}{b_{21}}$$

$$P_{27} = \frac{a_{12}}{b_{21}}$$

$$P_{28} = \frac{b_{22} + a_{14}}{b_{21}}$$

$$P_{29} = \frac{b_{33}}{b_{31}}$$

$$P_{30} = \frac{a_{23} - b_{34}}{b_{33}}$$

$$P_{31} = \frac{b_{35}}{b_{31}}$$

$$P_{32} = \frac{b_{36} - a_{21}}{b_{31}}$$

$$P_{33} = \frac{a_{22}}{b_{31}}$$

$$P_{34} = \frac{b_{32} + a_{24}}{b_{31}}$$

$$P_{35} = \frac{b_{13}}{b_{11}}$$

$$P_{36} = \frac{a_{33} - b_{14}}{b_{13}}$$

$$P_{37} = \frac{b_{15}}{b_{11}}$$

$$P_{38} = \frac{b_{16} - a_{31}}{b_{11}}$$

$$P_{39} = \frac{a_{32}}{b_{11}}$$

$$P_{40} = \frac{b_{12} + a_{34}}{b_{11}}$$

The model block diagram is shown in Fig. 5. The constants indicated in Fig. 5 are defined below, where the constants on the right hand side have been defined in the derivation of the equations.

$$L_1 = K_f + C_f T_{f1} - C_{ash} T_{ash} R_{hf}$$

$$L_2 = C_a T_a$$

$$L_3 = 1$$

$$L_4 = 1 - R_{hf}$$

$$L_5 = 4q_{gwo} T_{fo}^3 / (T_{fo}^4 - T_{1o}^4)$$

$$L_6 = T_{fo} / q_o$$

$$L_7 = T_{fo} / W_{go}$$

$$L_8 = 4T_{1o}^3 / (T_{fo}^4 - T_{1o}^4)$$

$$L_9 = 1 / P_w c_w V$$

$$L_{10} = K_{16} q_{Do} / T_{1o}$$

$$L_{11} = K_{15} q_{Do} / W_{Do}$$

$$L_{12} = K_{17} q_{Do} / D_{Do}$$

$$L_{13} = a_1 / (a_1 a_4 - a_2 a_3) = P_7$$

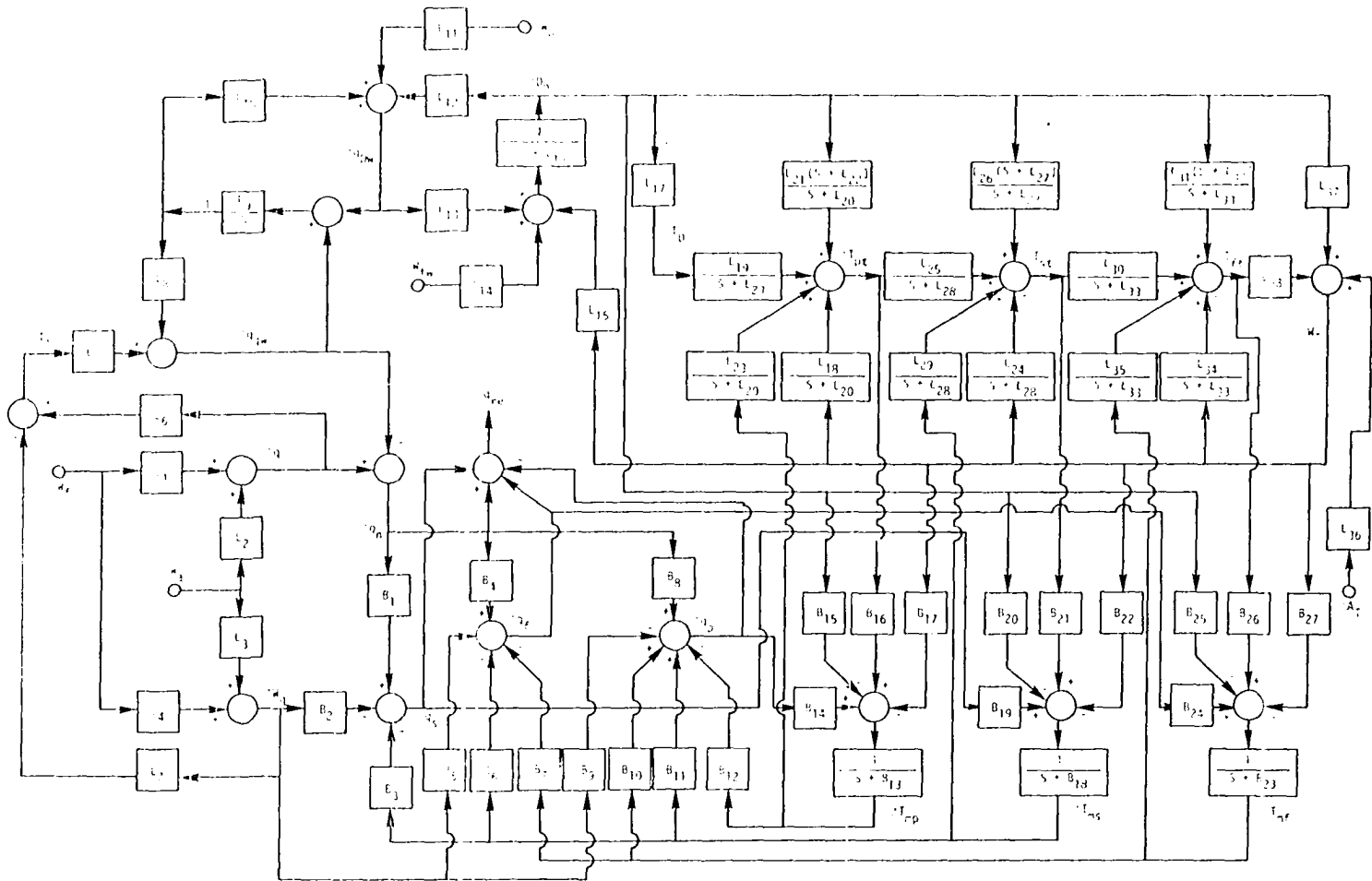

Fig. 5. A model for a drum type boiler.

$$L_{14} = (a_1 h_e - a_3) / (a_1 a_4 - a_2 a_3) = P_5$$

$$L_{15} = a_1 a_5 / (a_1 a_4 - a_2 a_3) = P_4$$

$$L_{16} = (a_1 h_{go} - a_3) / (a_1 a_4 - a_2 a_3) = P_6$$

$$L_{17} = T_{Do} v_{fgo} / h_{fgo}$$

$$L_{18} = (b_{16} - a_{31}) / b_{11} = P_{38}$$

$$L_{19} = b_{15} / b_{11} = P_{37}$$

$$L_{20} = (b_{12} + a_{34}) / b_{11} = P_{40}$$

$$L_{21} = b_{13} / b_{11} = P_{35}$$

$$L_{22} = (a_{33} - b_{14}) / b_{13} = P_{36}$$

$$L_{23} = a_{32} / b_{11} = P_{39}$$

$$L_{24} = (b_{26} - a_{11}) / b_{11}$$

$$L_{25} = b_{25} / b_{21} = P_{25}$$

$$L_{26} = b_{23} / b_{21} = P_{23}$$

$$L_{27} = (a_{13} - b_{24}) / b_{23} = P_{24}$$

$$L_{28} = (b_{22} + a_{14}) / b_{21} = P_{28}$$

$$L_{29} = a_{12} / b_{21} = P_{27}$$

$$L_{30} = b_{35} / b_{31} = P_{31}$$

$$L_{31} = b_{33} / b_{31} = P_{29}$$

$$L_{32} = (a_{23} - b_{34}) / b_{33} = P_{30}$$

$$L_{33} = (b_{33} + a_{24}) / b_{31} = P_{31}$$

$$L_{34} = (b_{36} - a_{21})/b_{31} = P_{32}$$

$$L_{35} = a_{22}/b_{31} = P_{33}$$

$$L_{36} = W_{To}/A_{To}$$

$$L_{37} = W_{To}/P_{To}$$

$$L_{38} = W_{To}/2T_{To}$$

$$B_1 = K_1$$

$$B_2 = K_3$$

$$B_3 = K_2$$

$$B_4 = K_4$$

$$B_5 = K_7$$

$$B_6 = K_5$$

$$B_7 = K_6$$

$$B_8 = K_8$$

$$B_9 = K_{12}$$

$$B_{10} = K_{10}$$

$$B_{11} = K_9$$

$$B_{12} = K_{11}$$

$$B_{13} = a_{32}/\rho_{mp} c_{mp} \bar{V}_{mp} = P_{12}$$

$$B_{14} = 1/\rho_{mp} c_{mp} \bar{V}_{mp} = P_8$$

$$B_{15} = a_{33}/\rho_{mp} c_{mp} \bar{V}_{mp} = P_9$$

$$B_{16} = a_{34} / \rho_{mp} c_{mp} V_{mp} = P_{10}$$

$$B_{17} = a_{31} / \rho_{mp} c_{mp} V_{mp} = P_{11}$$

$$B_{18} = P_{17}$$

$$B_{19} = P_{13}$$

$$B_{20} = P_{14}$$

$$B_{21} = P_{15}$$

$$B_{22} = P_{16}$$

$$B_{23} = P_{22}$$

$$B_{24} = P_{18}$$

$$B_{25} = P_{19}$$

$$B_{26} = P_{20}$$

$$B_{27} = P_{21}$$

The model developed here is through detailed analyses of boiler processes. A comparison of some features of physical models published in the 1970's (15,16,18,19,27) with the present model is given below.

a) Type of boiler considered:

Kwan and Anderson (15): drum-type, natural circulation.

Shang (27): once-through boiler.

Kwatny et al. (16) and McDonald and Kwatny (19): drum-type, forced circulation.

McDonald (18): drum-type, forced circulation.

Present: drum-type, forced circulation.

## b) Heat transfer through waterwall tubes:

Kwan and Anderson: thermal inertia of tube metal is considered.

Shang: thermal inertia of tube metal is considered.

McDonald and Kwatny: thermal inertia of tube metal is not considered.

McDonald: thermal inertia of tube metal is considered.

Present: thermal inertia of tube metal is considered.

## c) Fluid flow in waterwall tubes:

Kwan and Anderson: fluid flow rate is considered constant.

Shang: fluid flow rate is controlled.

McDonald and Kwatny: fluid flow rate is considered constant.

McDonald: fluid flow rate is considered constant.

Present: fluid flow rate is controlled.

## d) Drum pressure dynamics:

Kwan and Anderson: drum pressure is not an explicit state variable, but may be solved with a combination of model algebraic equations and integral equations.

Shang: (no drum)

McDonald and Kwatny: neither drum pressure nor steam temperature in drum is an output of model equations.

McDonald: drum pressure is an integral function of the rate of heat transfer to circulation fluid and the flow rate of steam out from the drum.

Present: drum pressure is a function of the rate of heat transfer to circulation fluid, the steam flow rate, and the feedwater flow rate; involving a delay.



## e) Superheater dynamics:

Kwan and Anderson: thermal inertia of tube metal is considered.

Shang: thermal inertia of tube metal is considered.

McDonald and Kwatny: thermal inertia of tube metal is not considered.

McDonald: dynamics of superheaters are not considered; throttle temperature is considered constant.

Present: thermal inertia of tube metal is considered.

## C. A Simplified Boiler Model

A simplified model may be not accurate enough to represent a boiler for the long periods required for control. They are useful in predicting the variation of boiler variables for shorter periods. One simplification is to treat the three superheaters as one section; then the model is reduced to that shown in Fig. 6.

A power plant boiler is usually equipped with an independent feedwater control loop such that the feedwater flow rate is equal to the steam flow rate. If this control is perfect and is considered as part of the boiler system, then

$$\Delta W_{fw} = \Delta W_T$$

and the model terminals  $\Delta W_{fw}$  and  $\Delta W_T$  can be connected together. Also, if the perturbation is small so that  $W_D$  may be kept as constant, then  $\Delta W_D = 0$ .

Further simplification of the model can be done on the gas side. If fuel and air flow control is perfect such that fuel flow rate is proportional to air flow rate, then

$$\Delta W_a = R_{fd} \Delta W_f$$

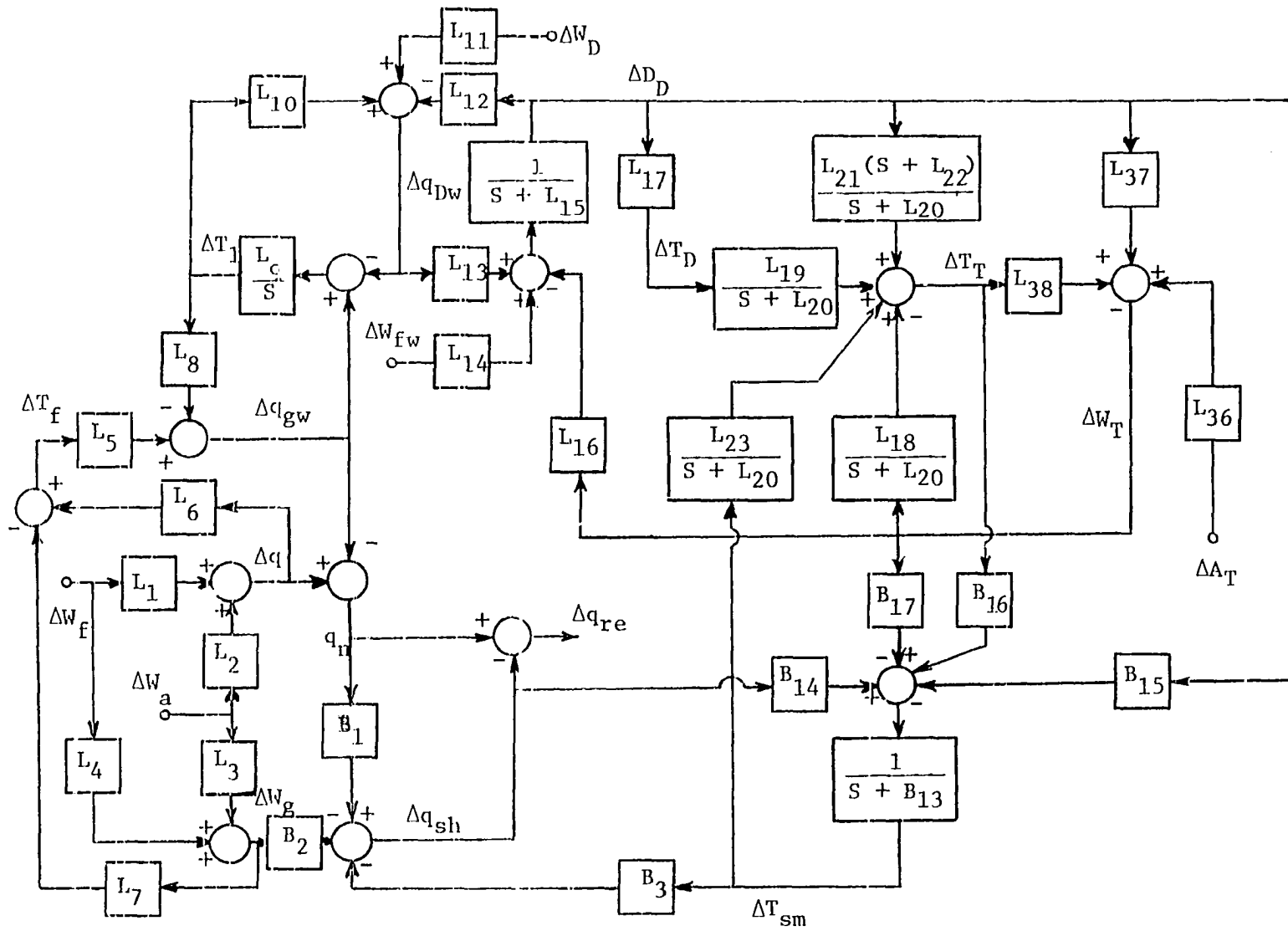

Fig. 6. Diagram of a simplified model.

and Eq. (2-A13) becomes

$$\Delta q = (K - C_a T_a R_{fa}) \Delta W_f \quad (3-C1)$$

where  $R_{fa}$  is air to fuel ratio. Also, during steady-state conditions, the heat transfer to each boiler section is a constant fraction of the total heat production in the furnace. If the proportionality is not changed for small boiler perturbations, then

$$\Delta q_{gw} = R_{gw} \Delta q = R_{gw} (K - C_a T_a R_{fa}) \Delta W_f \triangleq F_1 \Delta W_f \quad (3-C2)$$

$$\Delta q_{sh} = R_{sh} \Delta q = R_{sh} (K - C_a T_a R_{fa}) \Delta W_f \triangleq F_2 \Delta W_f \quad (3-C3)$$

where

$$R_{gw} < 1$$

and

$$R_{sh} < 1$$

are constants.

With these relations applied, the boiler model can be reduced to that shown in Fig. 7. where the two blocks involving  $L_{19}$  and  $L_{22}$  are also combined. Also, the loops enclosed in the dashed box can be reduced as given in Appendix C. Then the model becomes that shown in Fig. 8, where

$$F_3 = L_{21} L_{22} + L_{17} L_{19} \quad .$$

The lower summing function in Fig. 8 can be eliminated. Fig. 9 shows the direct result with elimination of this function.

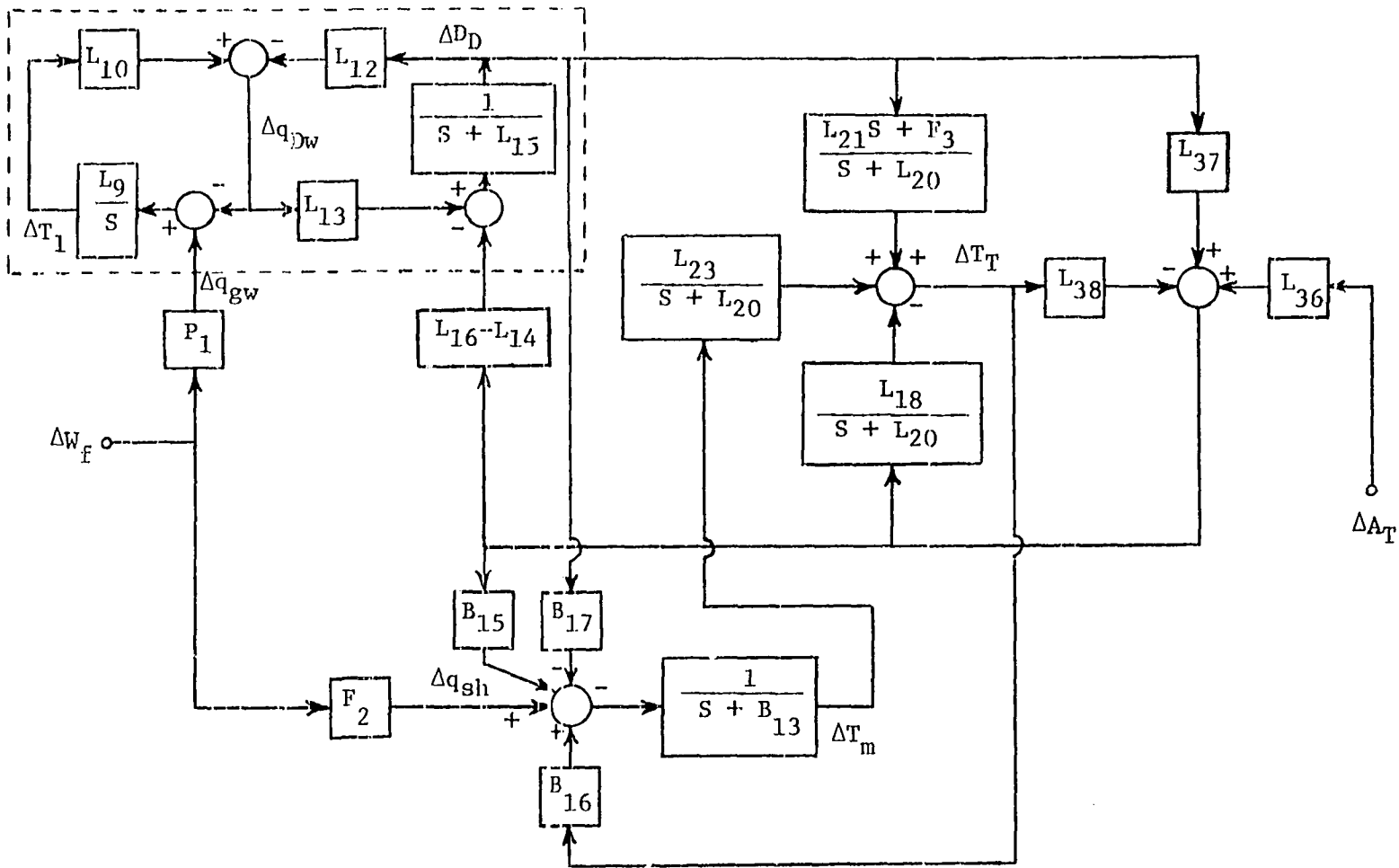

Fig. 7. Boiler model with simplification on gas processes.



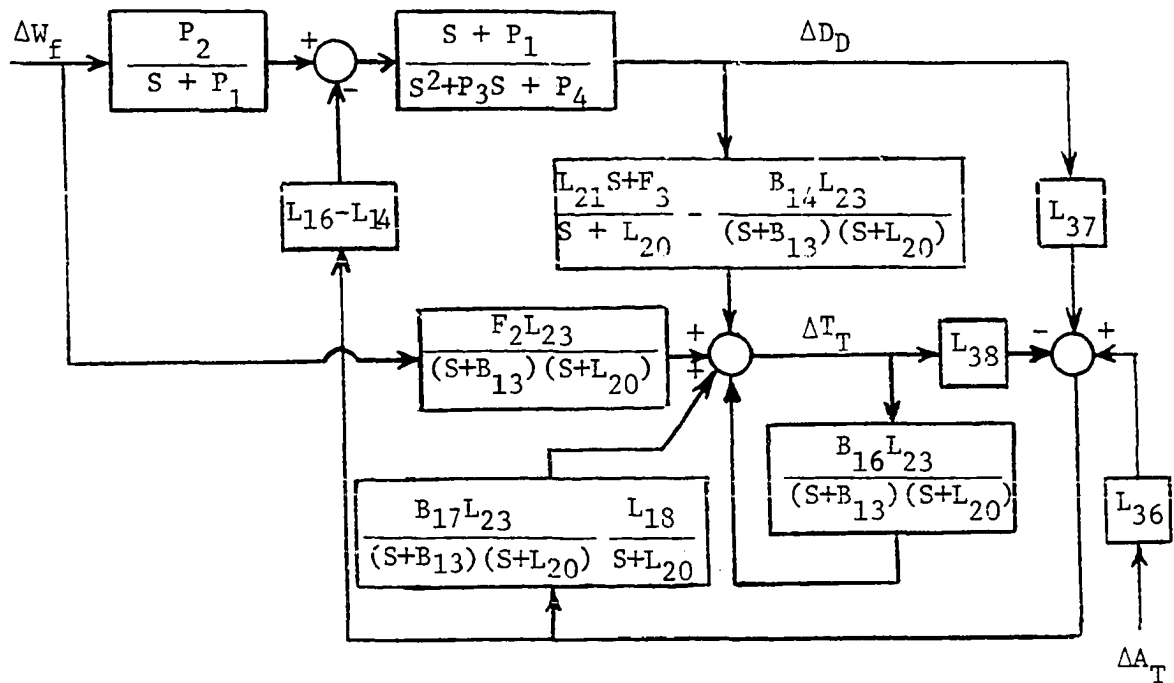
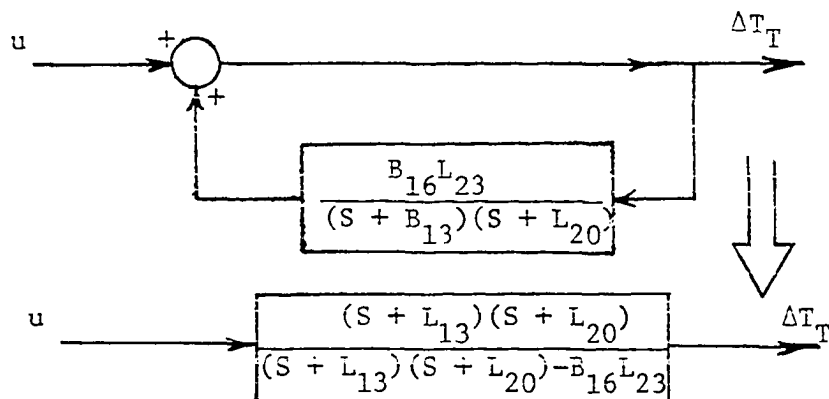

Fig. 9. Boiler model with lower summing junction in Fig. 8 eliminated.

The loop with  $\Delta T_T$  can be reduced, as shown below.



The model is finally reduced to that shown in Fig. 10.

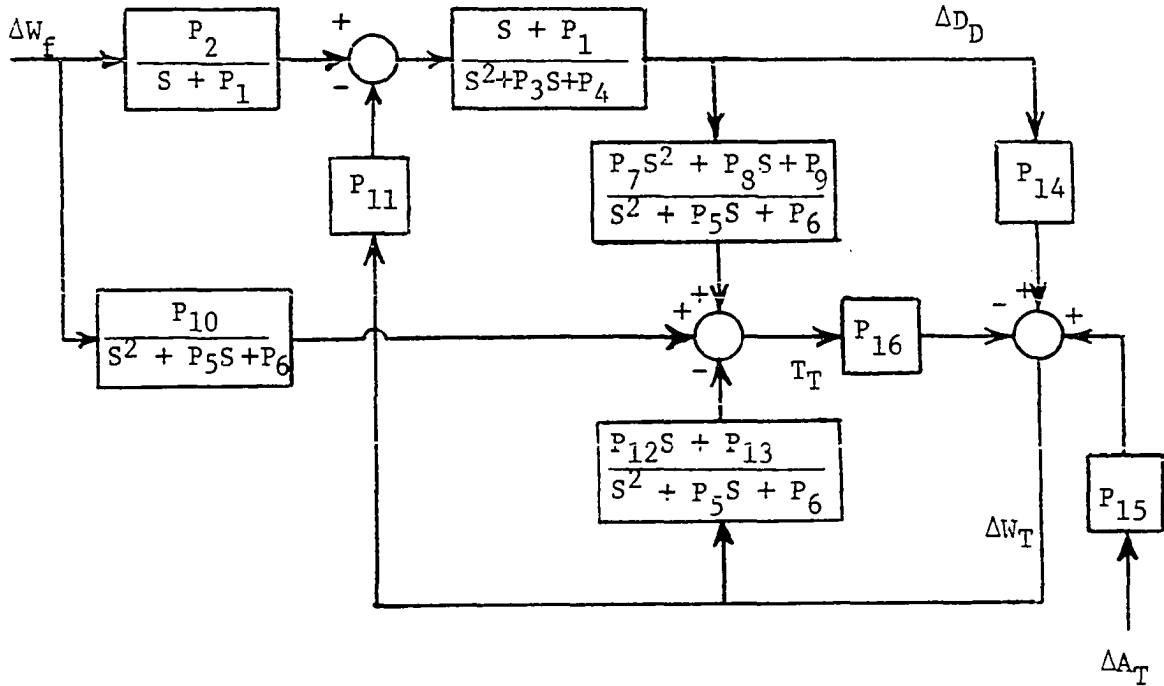

Fig. 10. The final simplified boiler model.

where

$$P_5 = B_{13} + L_{20}$$

$$P_6 = B_{13}L_{20} - B_{16}L_{23}$$

$$P_7 = L_{21}$$

$$P_8 = L_{21}B_{13} + F_3 = L_{21}L_{13} + L_{21}L_{22} + L_{17}L_{19}$$

$$P_9 = B_{13}F_3 - B_{15}L_{23} + B_{13}(L_{21}L_{22} + L_{17}L_{19}) - B_{15}L_{23}$$

$$P_{10} = F_2L_{23}$$

$$P_{11} = L_{16} - L_{14}$$

$$P_{12} = L_{18}$$

$$P_{13} = B_{13}L_{18} + B_{17}L_{23}$$

This is a low order model developed on physical principles.

The model inputs are

$\Delta W_f$  = fuel flow rate and

$\Delta A_T$  = control valve area,

and the model outputs are

$\Delta D_D$  = drum pressure,

$\Delta T_T$  = throttle temperature, and

$\Delta W_T$  = throttle steam flow rate.



## IV. DATA MEASUREMENT

Data of boiler dynamic responses are required for computation of model parameter constants. These data must be measured from a physical boiler at the points corresponding to the inputs and outputs of the model. Since the boiler model does not include transfer functions of control equipment and measurement equipment, the data recorded should be the direct reproduction of actual signals. In case distortion caused by measurement equipment is significant and only control signals are available, the transfer functions of the control and measurement equipment must be connected to the corresponding terminals of the boiler model. The model including the transfer functions of equipment should be used with the data for computing the parameter constants. This may not increase the number of unknown model parameters, since the transfer functions of the measurement equipment and the control equipment and their constants may be determined beforehand.

In making experimental tests, it must be carefully observed that the boiler system is in steady-state before the inputs are perturbed and the input and the output signals are recorded. It is desirable to obtain sets of boiler response data with each individual input perturbed as well as with a combination of several inputs perturbed simultaneously so that the sensitivity of individual inputs to the boiler dynamics and their combined effects on the system performances can be understood. The data set for parameter identification computation should include the following information:

Data for model inputs

- 1) fuel flow rate,
- 2) air flow rate,
- 3) control valve area,
- 4) feedwater flow rate, and
- 5) flow rate of circulation fluid.

Data for model outputs

- 1) throttle steam flow rate,
- 2) throttle steam temperature,
- 3) drum pressure, and
- 4) rate of heat flow to reheater and economizer sections.

ASME Performance Test Code and ASME Power Test Code may be followed to obtain the test data.

Fuel flow rate, air flow rate, control valve area, feedwater flow rate, throttle steam flow rate, and drum pressure generally can be measured with the equipment normally installed in the plant. The rate of heat flow to the reheater and economizer can not be measured directly. It has to be computed from the data measured for

- 1) temperature of the flue gas flowing into the reheater section,
- 2) temperature of the flue gas flowing into the economizer section,
- 3) mass flow rate of the flue gas into the reheater sections, and
- 4) mass flow rate of the flue gas into the economizer section.

The rate of heat flow into the respective sections then can be computed with Eqs. (2-A8) and (2-A9). The instrument for measuring these quantities is usually not installed in the plants.

The flow rate of circulation fluid usually can not be measured. Instruments have to be installed to make the test. It will be convenient if the transfer function relating the circulation fluid flow rate and the signal of the circulation pump driving motor input is obtained before the test. In this case the transfer function can be connected to the boiler model and the motor input becomes an input to the boiler, as shown in Fig. 11, where  $\Delta M_I$  is the motor input.

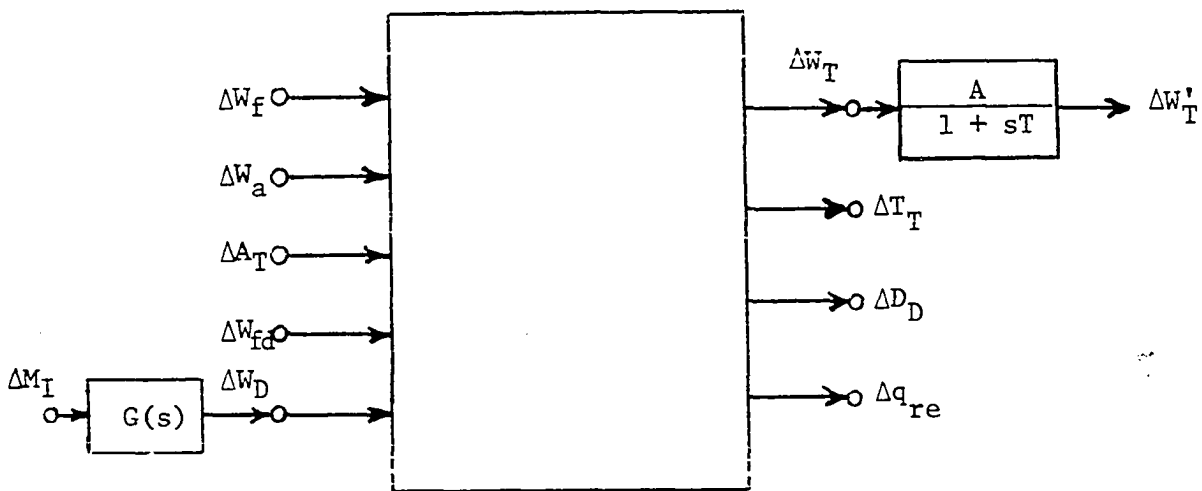

Fig. 11. Inputs and outputs of boiler model.

The throttle steam flow rate is proportional to the turbine first stage shell pressure corrected with the throttle temperature (2,26). A common practice is that the first stage pressure is measured and corrected to produce the data of steam flow rate. However, there is a time lag between the steam flow through the throttle valve and the detected variation of first stage pressure. The lag is mainly due to the existence of the

steam chest and the connecting pipe between the control valves and the turbine first-stage shell, as shown in Fig. 12.

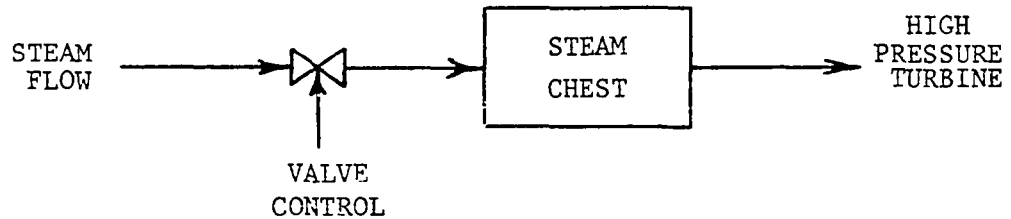

Fig. 12. Time lag exists between control valve steam flow and turbine first stage pressure.

This time lag appearing in the recorded data influences the results of identification computation if it is not properly treated. It has been suggested that this lag can be represented by a first order delay (13). A first order transfer function can be connected to the output  $\Delta W_T$  to represent this lag, as shown in Fig. 11, where  $\Delta W_T$  is the actual steam flow rate and  $\Delta \dot{w}_T^*$  is the measured steam flow rate.

Power plants are generally equipped with automatic controls such that the feedwater flow rate is controlled to equal the rate of steam flow out of the drum, and the air flow rate is controlled proportional to the fuel flow rate. If the controls are perfect, the information about feedwater flow rate and air flow rate become unnecessary. However, it is more desirable to have this information measured so that the actual situation is understood.

The test data should be recorded for a period of at least twenty minutes, as it sometimes takes about twenty minutes for a major thermal

transient to subside. Since the superheater controls are not included in the boiler model, superheater spray should be kept off during the experiment.

The boiler dynamic data should be recorded on analog magnetic tapes during the test so that they can be digitized later for digital computer application. It is trivial to mention that an experiment daily should be kept on file for the test. However, a portion or all of the data recorded will lose their value if the following information is not available:

- a) the environment pressure during the experiment must be known,
- b) the scale factors for all the records must be known,
- c) base lines which show steady-state levels of boiler variables must be shown clearly in all records,
- d) the physical values which the base lines represent must be known,
- e) the polarity of the recording voltage must be known,
- f) the formal recording on all data must start at the same time, and
- g) the location and length of each set of data on the tapes must be known.

Since a boiler is a large system and it is not always available for experiments, care must be taken to obtain this information in doing the experiment.

## V. CONCLUSIONS

A linear mathematical model for a thermal power plant drum type boiler has been developed. This model is intended for multivariable control studies on the boiler. It has included the pressure and temperature aspects of a boiler system. The dynamics of these pressure and temperature variables are important to control studies. Unlike the boiler models developed previously and discussed in Chapter I, in which some boiler controls are considered as a portion of the boiler, the boiler model developed here does not include controls. Some simplified boiler models are also presented. For these models, some external controls are included in the models so that assumptions can be made with the feedwater flow rate and the air flow rate. The simplified model may not be suitable for boiler control studies, but they may be used for an initial study of boiler dynamics.

The model is presented in closed compact form in the complex frequency domain, showing clearly the relationships among the boiler variables. Care has been taken in the model development that the boiler processes are described by a suitable set of boiler variables which not only represent the important boiler properties but also provide good relationships between the boiler components. Since the model is developed from physical principles, it can be used to represent boilers of the same configuration.

To compute the model constants for a particular boiler, dynamic input-output response data measured from experimental tests on the boiler are required to fit the model. The parameter identification technique is available for computation of the model constants. Initial estimates of the parameter constants, which are required for the parameter identification

program, can be calculated from boiler design data. The relations between the model parameters and the physical quantities of the boiler have been defined in the model development. The computed model parameter values are the effective dynamic constants of the boiler processes which give the corresponding input-output relations.

The dynamic response data for the inputs and the outputs of the boiler model are necessary for computation of the model constants. It is desirable if data are available for the other boiler variables so that the parameter computation can also be done on a partitioned model. In the measurement of the transient pressure and the transient temperature, care must be taken in visualizing the possible time delay appearing in the recorded signal which is usually caused by the sensing the measurement system. These delays should be properly corrected for application to parameter identification computation.

## VI. LITERATURE CITED

1. Anderson, P. M. Modeling Thermal Power Plants for Dynamic Stability Studies. Ames, Iowa: Cyclone Copy Center, c 1974. (Available from author, EPRI, Palo Alto, Ca.)
2. Barlett, R. L. Steam Turbines Performance and Economics. New York: McGraw-Hill Book Company, 1958.
3. Baumeister, T. and L. S. Marks, ed. Standard Handbook for Mechanical Engineers. 7th ed. New York: McGraw-Hill Book Company, 1967.
4. Berkowitz, D. A., ed. Proceedings of the Seminar on Boiler Modeling. Bedford, Mass.: The MITRE Corporation, 1974.
5. Chien, K. L.; Ergin, E. I.; Ling, C.; and Lee, A. "Dynamic Analysis of a Boiler." ASME Trans. 80 (1958): 1809-1819.
6. Clelland, P. J.; and Kwatny, H. G. "Modeling and Simulation of Gas Dynamics in a Fossil-Fuel Power Boiler." Proceedings of the 28th Annual ISA Conference, Philadelphia, Pa., 1973.
7. Daniels, J. H.; Enns, M.; and Hottenstine, R. D. "Dynamic Representation of a Large Boiler-Turbine Unit." ASME Paper No. 61-SA-69, ASME Summer Annual Meeting, Los Angeles, California, 1961.
8. de Mello, F. P.; and Imad, F. P. "Boiler Pressure Control Configurations." IEEE Paper No. 31 PP67-12, IEEE Winter Power Meeting, New York, N.Y., 1967.
9. de Mello, F. P.; Mills, R. J.; and B'rells, W. F. "Automatic Generation Control; Part I—Process Modeling." IEEE Trans. on Power Apparatus and Systems, PAS-92 (1973): 710-715.
10. Eklund, K.; and Gustavsson, I. "Identification of Drum Boiler Dynamics." Proceedings of the 3rd IFAC Symposium on Identification and System Parameter Estimation. The Hague/Delft, the Netherlands: American Elsevier Publishing Co., Inc., 1973.
11. Enns, M. "Comparison of Dynamic Models of a Superheater." ASME Paper No. 61-WA-171. ASME Winter Annual Meeting, New York, N.Y., 1961.
12. Frogner, B. "System Identification, Estimation and Optimal Control of a Nuclear Boiling Water Reactor." Ph.D. Dissertation, University of California, Berkeley. 1974.
13. IEEE Committee Report. "Dynamic Models for Steam and Hydro Turbines in Power System Studies." IEEE Trans. on Power Apparatus and Systems, PAS-92 (1973): 1904-1915.



14. Kearton, W. J. Steam Turbine Theory and Practice. 7th ed. London: Sir Issac Pitman & Sons, Ltd., 1961.
15. Kwan, H. W.; and Anderson, J. H. "A Mathematical Model of a 200 mW Boiler." International Journal of Control, 12 (1970): 977-998.
16. Kwatny, H. G.; McDonald, J. P.; and Spare, J. H. "A Nonlinear Model for Reheat Boiler-turbine-generator Systems; Part II—Development." Proceedings of the 12th Joint Automatic Control Conference, St. Louis, Mo., 1971.
17. Laubli, F.; and Fenton, F. H., Jr. "The Flexibility of the Super-critical Boiler as a Partner in Power System Design and Operation; Part I—Theoretical Relationships." IEEE Trans. on Power Apparatus and Systems, PAS-90 (1971): 1719-1724.
18. McDonald, J. P. "Turbine-Boiler Representation." IEEE Publication CHO 970-4-PWR. Symposium on Adequacy and Philosophy of Modeling: System Dynamic Performance, New York, N.Y., 1975.
19. McDonald, J. P.; and Kwatny, H. G. "A Mathematical Model for Reheat Boiler-turbine-generator Systems." IEEE Paper No. 70 CP 221-PWR. IEEE Winter Power Meeting, New York, N.Y., 1970.
20. McDonald, J. P.; Kwatny, H. G.; and Spare, J. H. "A Nonlinear Model for Reheat Boiler-turbine-generator Systems; Part I—General Description and Evaluation." Proceedings of the 12th Joint Automatic Control Conference, St. Louis, Mo., 1971.
21. Olsson, G. "Modeling and Identification of Nuclear Power Reactor Dynamics from Multivariable Experiments." Proceedings of the 3rd IFAC Symposium on Identification and System Parameter Estimation. The Hague/Delft, the Netherlands: American Elsevier Publishing Co., Inc., 1973.
22. Park, C. U. "Parameter Identification of Low-Order Boiler Models for Dynamic Stability Analysis." Ph.D. Dissertation, Iowa State University, 1975.
23. Profos, P. "Dynamics of Pressure and Combustion Control in Steam Generators." Sulzer Technical Review, 37, No. 4 (1955): 1-15.
24. Rao, H. S.; Frogner, B.; Gupta, N. K.; and Carmichael, L. A. "Parameter Identification in the BWR." Proceedings of the 2nd Power Plant Dynamics, Control and Testing Symposium, Knoxville, Tenn., 1975.
25. Roman, W. S.; Hsu, C.; and Hebegger, L. F. "Parameter Identification in a Nonlinear Reactor System." IEEE Trans. on Nuclear Science, NS-18 (1971): 426-429.

26. Salisbury, J. K. Steam Turbines and Their Cycles. New York: John Wiley & Sons, Inc., 1950.
27. Shang, T. L. "A Dynamic Model of Once-through Supercritical Pressure Boiler." Dissertation for Doctor of Technical Sciences, Swiss Federal Institute of Technology, 1971.
28. Shields, C. D. Boiler: Types, Characteristics, and Functions. New York: F. W. Dodge Corporation, 1961.
29. Thal-Larson, H. "Dynamics of Heat Exchangers and Their Models." ASME Trans. 82, Series D (1960): 489-504.
30. Thompson, F. T. "A Dynamic Model for Control of a Drum-type Boiler System." Ph.D. Dissertation, University of Pittsburgh, 1964.
31. Thompson, F. T. "A Dynamic Model of a Drum-type Boiler System." IEEE Trans. on Power Apparatus and Systems, PAS-86 (1967): 625-635.

## VII. ACKNOWLEDGMENTS

The author would like to express acknowledgments and thanks to his major professor, Dr. Charles J. Herget, for his help and guidance. The discussion of the problems with Professor A. W. Joensen and Mr. Minh Luu of the Mechanical Engineering Department is appreciated.

This part of the research is financially supported by the Affiliate Research Program in Electric Power of the Engineering Research Institute of Iowa State University.

APPENDIX A. TRANSFER FUNCTION FOR WATERWALL TUBE WALL  
DIVIDED INTO THREE LAYERS

Equation (2-D4) can be written as

$$\frac{d}{dt} \begin{bmatrix} \Delta T_1 \\ \Delta T_2 \\ \Delta T_3 \end{bmatrix} = \begin{bmatrix} -\frac{A_1 h_1}{\rho_1 c_1 V_1} & \frac{A_2 h_2}{\rho_1 c_1 V_1} & 0 \\ \frac{A_1 h_1}{\rho_2 c_2 V_2} - \frac{(A_1 h_1 + A_2 h_2)}{\rho_2 c_2 V_2} & \frac{A_2 h_2}{\rho_2 c_2 V_2} & \\ 0 & \frac{A_2 h_2}{\rho_3 c_3 V_3} & \frac{-A_3 h_3}{\rho_3 c_3 V_3} \end{bmatrix} \begin{bmatrix} \Delta T_1 \\ \Delta T_2 \\ \Delta T_3 \end{bmatrix} + \begin{bmatrix} \frac{1}{\rho_1 c_1 V_1} & 0 \\ 0 & 0 \\ 0 & \frac{-1}{\rho_3 c_3 V_3} \end{bmatrix} \begin{bmatrix} \Delta q_{gw} \\ \Delta q_{Dw} \end{bmatrix} \quad (\text{A-1})$$

Equation (2-E6) is

$$\Delta q_{Dw} = K_{19} \Delta T_3 + K_{18} \Delta W_D - K_{20} \Delta D_D \quad (\text{A-2})$$

Combining Eqs. (A-1) and (A-2), eliminating  $\Delta q_{Dw}$

$$\frac{d}{dt} \begin{bmatrix} \Delta T_1 \\ \Delta T_2 \\ \Delta T_3 \end{bmatrix} = \begin{bmatrix} -\frac{A_1 h_1}{\rho_1 c_1 V_1} & \frac{A_2 h_2}{\rho_1 c_1 V_1} & 0 \\ \frac{A_1 h_1}{\rho_2 c_2 V_2} - \frac{(A_1 h_1 + A_2 h_1)}{\rho_2 c_2 V_2} & \frac{A_2 h_2}{\rho_2 c_2 V_2} & \\ 0 & \frac{A_2 h_2}{\rho_3 c_3 V_3} & \frac{-(A_3 h_3 + K_{19})}{\rho_3 c_3 V_3} \end{bmatrix} \begin{bmatrix} \Delta T_1 \\ \Delta T_2 \\ \Delta T_3 \end{bmatrix}$$

$$+ \begin{bmatrix} \frac{1}{\rho_1 c_1 V_1} & 0 & 0 \\ 0 & 0 & 0 \\ 0 & \frac{-K_{18}}{\rho_3 c_3 V_3} & \frac{K_{20}}{\rho_3 c_3 V_3} \end{bmatrix} \begin{bmatrix} \Delta q_{gw} \\ \Delta W_D \\ \Delta D_D \end{bmatrix} \quad (A-3)$$

where  $\Delta q_{gw}$ ,  $\Delta W_D$ , and  $\Delta D_D$  are the inputs to this subsystem, and Eq. (A-2) is the output equation.

To express this subsystem in the form of transfer functions, the state-space equations can be transformed to

$$\Delta T_1(s) = \frac{1}{s + \frac{A_1 h_1}{\rho_1 c_1 V_1}} \left[ \frac{A_2 h_2}{\rho_1 c_1 V_1} \Delta T_2(s) + \frac{1}{\rho_1 c_1 V_1} \Delta q_{gw}(s) \right] \quad (A-4)$$

$$\Delta T_2(s) = \frac{1}{s + \frac{A_1 h_1 + A_2 h_2}{\rho_2 c_2 V_2}} \left[ \frac{A_1 h_1}{\rho_2 c_2 V_2} \Delta T_1(s) + \frac{A_2 h_2}{\rho_2 c_2 V_2} \Delta T_3(s) \right] \quad (A-5)$$

$$\Delta T_3(s) = \frac{1}{s + \frac{A_3 h_3 + K_{19}}{\rho_3 c_3 V_3}} \left[ \frac{A_2 h_2}{\rho_3 c_3 V_3} \Delta T_2(s) - \frac{K_{18}}{\rho_3 c_3 V_3} \Delta W_D(s) + \frac{K_{20}}{\rho_3 c_3 V_3} \Delta D_D(s) \right] \quad (A-6)$$

Substitute Eq. (A-4) into Eq. (A-5) and rearrange,

$$\Delta T_2(s) = \frac{\frac{1}{\rho_2 c_2 V_2}}{s^2 + \left( \frac{A_1 h_1}{\rho_1 c_1 V_1} + \frac{A_1 h_1 + A_2 h_2}{\rho_2 c_2 V_2} \right) s + \frac{A_1^2 h_1^2}{\rho_1 c_1 V_1 \rho_2 c_2 V_2}} \quad \times$$

$$\left[ \frac{A_2 h_2 \left( s + \frac{A_1 h_1 + A_2 h_2}{\rho_1 c_1 V_1} \right) \left( s + \frac{A_1 h_1}{\rho_1 c_1 V_1} \right)}{s + \frac{A_1 h_1 + A_2 h_2}{\rho_2 c_2 V_2}} \Delta T_3(s) + \frac{A_1 h_1}{\rho_1 c_1 V_1} \Delta q_{gw}(s) \right] \quad (\text{A-7})$$

Substitute Eq. (A-7) into Eq. (A-6) and rearrange,

$$T_3(s) = \frac{1}{s^4 + P_1 s^3 + P_2 s^2 + P_3 s + P_4} \left[ P_5(s + P_6) \Delta q_{gw}(s) - (s^3 + P_7 s^2 + P_8 s + P_9) (P_{10} \Delta W_D(s) - P_{11} \Delta D_D(s)) \right] \quad (\text{A-8})$$

where

$$P_1 = \frac{A_3 h_3 + K_{19}}{\rho_3 c_3 V_3} + 2 \frac{A_1 h_1 + A_2 h_2}{\rho_2 c_2 V_2} + \frac{A_1 h_1}{\rho_1 c_1 V_1}$$

$$P_2 = \frac{(A_3 h_3 + K_{19})(A_1 h_1 + A_2 h_2)}{\rho_2 c_2 V_2 \rho_3 c_3 V_3} + \left( \frac{A_1 h_1}{\rho_1 c_1 V_1} + \frac{A_1 h_1 + A_2 h_2}{\rho_2 c_2 V_2} \right) \times$$

$$\left( \frac{A_3 h_3 + K_{19}}{\rho_3 c_3 V_3} + \frac{A_1 h_1 + A_2 h_2}{\rho_2 c_2 V_2} \right) + \frac{A_1^2 h_1^2}{\rho_1 c_1 V_1 \rho_2 c_2 V_2} - \frac{A_2^2 h_2^2}{\rho_2 c_2 V_2 \rho_3 c_3 V_3}$$

$$P_3 = \frac{A_1^2 h_1^2 (A_3 h_3 + K_{19})}{\rho_1 c_1 V_1 \rho_2 c_2 V_2 \rho_3 c_3 V_3} + \left( \frac{A_1 h_1}{\rho_1 c_1 V_1} + \frac{A_1 h_1 + A_2 h_2}{\rho_2 c_2 V_2} \right) \times$$

$$\begin{aligned}
& \frac{(A_3 h_3 + K_{19})(A_1 h_1 + A_2 h_2)}{\rho_2 c_2 V_2 \rho_3 c_3 V_3} + \frac{A_1^2 h_1^2 (A_1 h_1 + A_2 h_2)}{\rho_1 c_1 V_1 (\rho_2 c_2 V_2)^2} \\
& - \frac{A_2^2 h_2^2}{\rho_2 c_2 V_2 \rho_3 c_3 V_3} \left( \frac{A_1 h_1 + A_2 h_2}{\rho_1 c_1 V_1 \rho_2 c_2 V_2} + \frac{A_1 h_1}{\rho_1 c_1 V_1} \right) \\
P_4 = & \frac{A_1^2 h_1^2 (A_3 h_3 + K_{19})(A_1 h_1 + A_2 h_2)}{\rho_1 c_1 V_1 (\rho_2 c_2 V_2)^2 \rho_3 c_3 V_3} - \frac{A_1 h_1 (A_2 h_2)^2 (A_1 h_1 + A_2 h_2)}{(\rho_1 c_1 V_1 \rho_2 c_2 V_2)^2 \rho_3 c_3 V_3} \\
P_5 = & \frac{A_1 h_1 A_2 h_2}{\rho_1 c_1 V_1 \rho_2 c_2 V_2 \rho_3 c_3 V_3} \\
P_6 = & \frac{A_1 h_1 + A_2 h_2}{\rho_2 c_2 V_2} \\
P_7 = & 2 \frac{A_1 h_1 + A_2 h_2}{\rho_2 c_2 V_2} + \frac{A_1 h_1}{\rho_1 c_1 V_1} \\
P_8 = & \left( \frac{A_1 h_1}{\rho_1 c_1 V_1} + \frac{A_1 h_1 + A_2 h_2}{\rho_2 c_2 V_2} \right) \left( \frac{A_1 h_1 + A_2 h_2}{\rho_2 c_2 V_2} \right) + \frac{A_1^2 h_1^2}{\rho_1 c_1 V_1 \rho_2 c_2 V_2} \\
P_9 = & \frac{A_1^2 h_1^2 (A_1 h_1 + A_2 h_2)}{\rho_1 c_1 V_1 (\rho_2 c_2 V_2)^2} \\
P_{10} = & \frac{K_{18} A_1 h_1 A_2 h_2}{\rho_1 c_1 V_1 \rho_2 c_2 V_2 \rho_3 c_3 V_3} \\
P_{11} = & \frac{K_{20} A_1 h_1 A_2 h_2}{\rho_1 c_1 V_1 \rho_2 c_2 V_2 \rho_3 c_3 V_3}
\end{aligned}$$

APPENDIX B. TRANSFER FUNCTION FOR A SUPERHEATER TUBE WALL  
DIVIDED INTO THREE LAYERS

From Eq. (2-D4)

$$\frac{d}{dt} \begin{bmatrix} \Delta T_1 \\ \Delta T_2 \\ \Delta T_3 \end{bmatrix} = \begin{bmatrix} \frac{-A_1 h_1}{\rho_1 c_1 V_1} & \frac{A_2 h_2}{\rho_1 c_1 V_1} & 0 \\ \frac{A_1 h_1}{\rho_2 c_2 V_2} & \frac{-(A_1 h_1 + A_2 h_2)}{\rho_2 c_2 V_2} & \frac{A_2 h_2}{\rho_2 c_2 V_2} \\ 0 & \frac{A_2 h_2}{\rho_3 c_3 V_3} & \frac{-A_3 h_3}{\rho_3 c_3 V_3} \end{bmatrix} \begin{bmatrix} \Delta T_1 \\ \Delta T_2 \\ \Delta T_3 \end{bmatrix} + \begin{bmatrix} \frac{1}{\rho_1 c_1 V_1} & 0 \\ 0 & 0 \\ 0 & \frac{-1}{\rho_3 c_3 V_3} \end{bmatrix} \begin{bmatrix} \Delta q_{gsh} \\ \Delta q_{Dsh} \end{bmatrix} \quad (B-1)$$

Equation (2-E5) can be written as

$$\Delta q_{Dsh} = K_{14} \Delta T_3 + K_{13} \Delta W_v + K_{15} \Delta D_D - K_{16} \Delta T_{sh} \quad (B-2)$$

Substitute Eq. (B-2) into Eq. (B-1)

$$\frac{d}{dt} \begin{bmatrix} \Delta T_1 \\ \Delta T_2 \\ \Delta T_3 \end{bmatrix} = \begin{bmatrix} \frac{-A_1 h_1}{\rho_1 c_1 V_1} & \frac{A_2 h_2}{\rho_1 c_1 V_1} & 0 \\ \frac{A_1 h_1}{\rho_2 c_2 V_2} & \frac{-(A_1 h_1 + A_2 h_2)}{\rho_2 c_2 V_2} & \frac{A_2 h_2}{\rho_2 c_2 V_2} \\ 0 & \frac{A_2 h_2}{\rho_3 c_3 V_3} & \frac{-(A_3 h_3 + K_{14})}{\rho_3 c_3 V_3} \end{bmatrix} \begin{bmatrix} \Delta T_1 \\ \Delta T_2 \\ \Delta T_3 \end{bmatrix}$$



$$+ \begin{bmatrix} \frac{1}{\rho_1 c_1 V_1} & 0 & 0 & 0 \\ 0 & 0 & 0 & 0 \\ 0 & \frac{-K_{13}}{\rho_3 c_3 V_3} & \frac{K_{15}}{\rho_3 c_3 V_3} & \frac{K_{16}}{\rho_3 c_3 V_3} \end{bmatrix} \begin{bmatrix} \Delta q_{sh} \\ \Delta W_v \\ \Delta D_D \\ \Delta T_{sh} \end{bmatrix} \quad (B-3)$$

where  $\Delta q_{sh}$ ,  $\Delta W_v$ ,  $\Delta D_D$ ,  $\Delta T_{sh}$  are the inputs and Eq. (B-2) is the output equation.

Following the same approach as in Appendix A, the following result is obtained,

$$\Delta T_3(s) = \frac{1}{s^4 + P_1 s^3 + P_2 s^2 + P_3 s + P_4} \left[ P(s + P_6) \Delta q_{gsh}(s) - (s^3 + P_7 s^2 + P_8 s + P_9) (P_{10} \Delta W_v(s) + P_{11} \Delta D_D(s) - P_{12} \Delta T_{sh}(s)) \right]$$

where

$$P_1 = \frac{A_3 h_3 + K_{14}}{\rho_3 c_3 V_3} + 2 \frac{A_1 h_1 + A_2 h_2}{\rho_2 c_2 V_2} + \frac{A_1 h_1}{\rho_1 c_1 V_1}$$

$$P_2 = \frac{(A_3 h_3 + K_{14})(A_1 h_1 + A_2 h_2)}{\rho_2 c_2 V_2 \rho_3 c_3 V_3} + \frac{A_1 h_1}{\rho_1 c_1 V_1} + \frac{A_1 h_1 + A_2 h_2}{\rho_2 c_2 V_2} \times$$

$$\left( \frac{A_3 h_3 + K_{14}}{\rho_3 c_3 V_3} + \frac{A_1 h_1 + A_2 h_2}{\rho_2 c_2 V_2} \right) + \frac{A_1^2 h_1^2}{\rho_1 c_1 V_1 \rho_2 c_2 V_2} - \frac{A_2^2 h_2^2}{\rho_2 c_2 V_2 \rho_3 c_3 V_3}$$

$$P_3 = \frac{A_1^2 h_1^2 (A_1 h_1 + A_2 h_2)}{\rho_1 c_1 V_1 \rho_2 c_2 V_2 \rho_3 c_3 V_3} + \left( \frac{A_1 h_1}{\rho_1 c_1 V_1} + \frac{A_1 h_1 + A_2 h_2}{\rho_2 c_2 V_2} \right) \times$$

$$\frac{(A_3 h_3 + K_{14})(A_1 h_1 + A_2 h_2)}{\rho_2 c_2 V_2 \rho_3 c_3 V_3} + \frac{A_1^2 h_1^2 (A_1 h_1 + A_2 h_2)}{\rho_1 c_1 V_1 (\rho_2 c_3 V_2)^2}$$

$$\begin{aligned}
& - \frac{A_2^2 h_2^2}{\rho_2^2 c_2^2 v_2 \rho_3 c_3 v_3} \left( \frac{A_1 h_1 + A_2 h_2}{\rho_1 c_1 v_1 \rho_2 c_2 v_2} + \frac{A_1 h_1}{\rho_1 c_1 v_1} \right) \\
P_4 &= \frac{A_2^2 h_2^2 (A_3 h_3 + K_{14}) (A_1 h_1 + A_2 h_2)}{\rho_1 c_1 v_1 (\rho_2 c_2 v_2)^2 \rho_3 c_3 v_3} - \frac{A_1 h_1 (A_2 h_2)^2 (A_1 h_1 + A_2 h_2)}{(\rho_1 c_1 v_1 \rho_2 c_2 v_2)^2 \rho_3 c_3 v_3} \\
P_5 &= \frac{A_1 h_1 A_2 h_2}{\rho_1 c_1 v_1 \rho_2 c_2 v_2 \rho_3 c_3 v_3} \\
P_6 &= \frac{A_1 h_1 + A_2 h_2}{\rho_2 c_2 v_2} \\
P_7 &= 2 \frac{A_1 h_1 + A_2 h_2}{\rho_2 c_2 v_2} + \frac{A_1 h_1}{\rho_1 c_1 v_1} \\
P_8 &= \left( \frac{A_1 h_1}{\rho_1 c_1 v_1} + \frac{A_1 h_1 + A_2 h_2}{\rho_2 c_2 v_2} \right) \left( \frac{A_1 h_1 + A_2 h_2}{\rho_2 c_2 v_2} \right) + \frac{A_1^2 h_1^2}{\rho_1 c_1 v_1 \rho_2^2 c_2^2 v_2^2} \\
P_9 &= \frac{A_1^2 h_1^2 (A_1 h_1 + A_2 h_2)}{\rho_1 c_1 v_1 (\rho_2 c_2 v_2)^2} \\
P_{10} &= \frac{\bar{K}_{13} A_1 h_1 A_2 h_2}{\rho_1 c_1 v_1 \rho_2 c_2 v_2 \rho_3 c_3 v_3} \\
P_{11} &= \frac{K_{15} A_1 h_1 A_2 h_2}{\rho_1 c_1 v_1 \rho_2 c_2 v_2 \rho_3 c_3 v_3} \\
P_{12} &= \frac{K_{16} A_1 h_1 A_2 h_2}{\rho_1 c_1 v_1 \rho_2 c_2 v_2 \rho_3 c_3 v_3}
\end{aligned}$$

## APPENDIX C. REDUCTION OF TRANSFER FUNCTION BLOCKS

To reduce the blocks

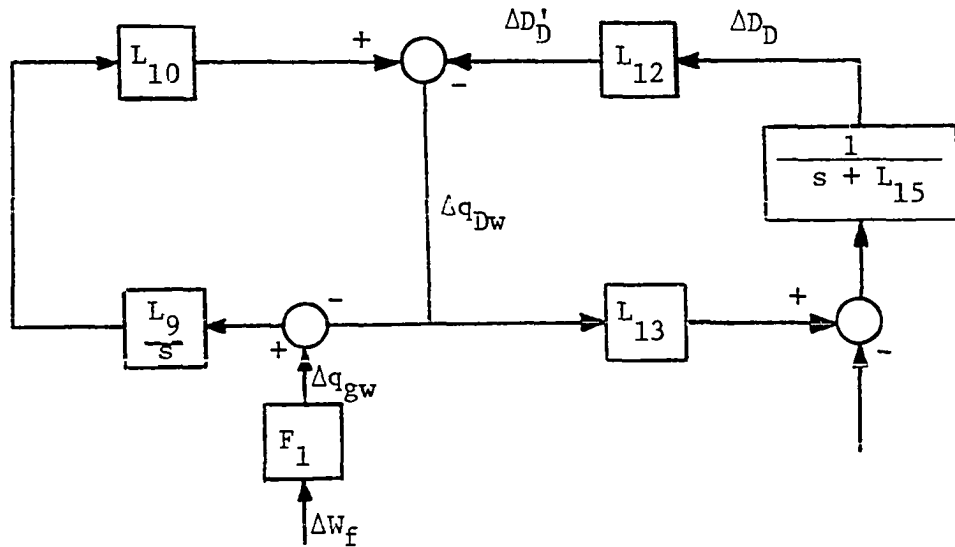

The left loop can be written as

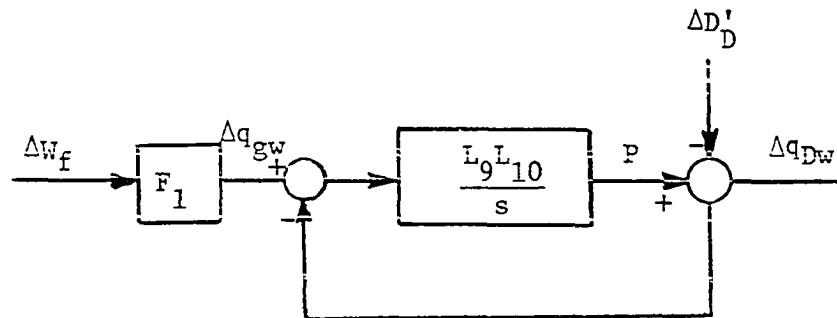

$$\{\Delta q_{gw}(s) - [P(s) - \Delta D'_D(s)]\} \frac{L_9 L_{10}}{s} = P(s)$$

$$[\Delta q_{gw}(s) + \Delta D'_D(s)] \frac{L_9 L_{10}}{s} = \frac{s + L_9 L_{10}}{s} P(s)$$

$$[\Delta q_{gw}(s) + \Delta D'_D(s)] \frac{L_9 L_{10}}{s + L_9 L_{10}} = P(s)$$

Subtract  $\Delta D'_D(s)$  from both sides,

$$\Delta q_{gw}(s) \frac{L_9 L_{10}}{s + L_9 L_{10}} - \Delta D'_D(s) \frac{s}{s + L_9 L_{10}} = \Delta P(s) - \Delta D'_D(s) = \Delta q_{Dw}(s)$$

the original blocks become

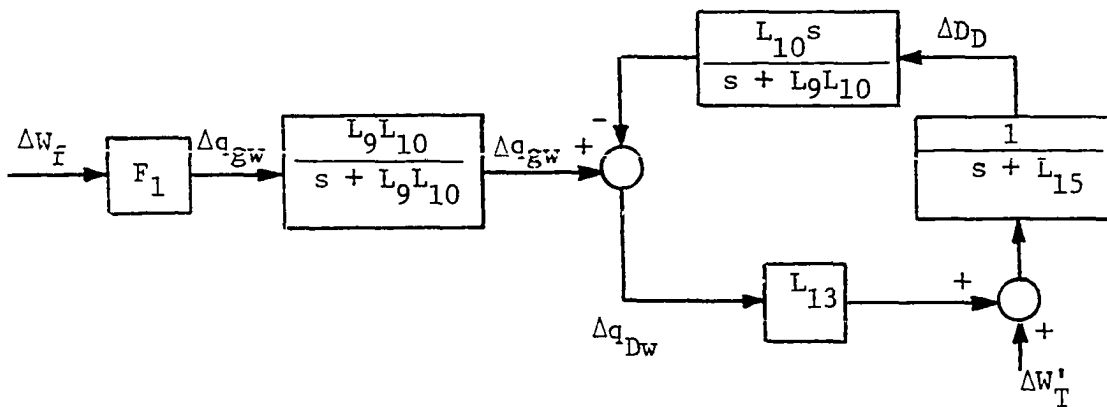

The loop on the right can be written as

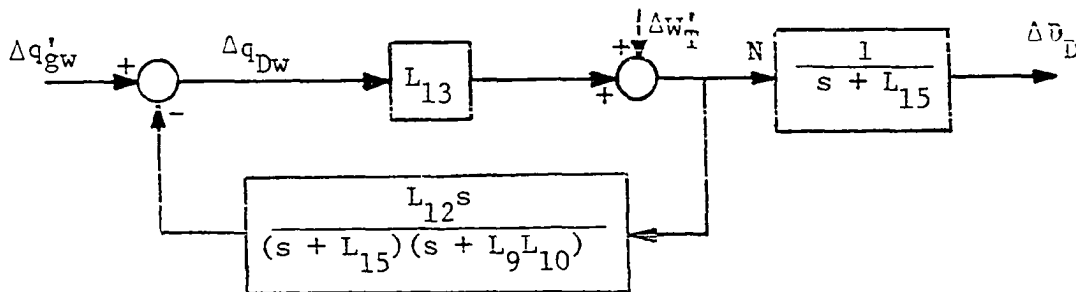

$$\Delta q'_{gw}(s) - (L_{13} \Delta q_{Dw}(s) - \Delta W'_T(s)) \frac{L_{12} s}{(s + L_{15})(s + L_9 L_{10})} = \Delta q_{Dw}$$

$$\Delta q'_{gw}(s) + \Delta W'_T(s) \frac{L_{12} s}{(s + L_{15})(s + L_9 L_{10})}$$

$$\begin{aligned}
&= \frac{L_{12}L_{13}s + (s + L_{15})(s + L_9L_{10})}{(s + L_{15})(s + L_9L_{10})} \Delta q_{Dw}(s) \\
\Delta q'_{gw}(s) &\frac{(s + L_{15})(s + L_9L_{10})}{(s + L_{15})(s + L_9L_{10}) + L_{12}L_{13}s} \\
&+ \Delta W'_T(s) \frac{L_{12}s}{(s + L_{15})(s + L_9L_{10}) + L_{12}L_{13}s} = \Delta q_{Dw}
\end{aligned}$$

Multiply both sides by  $L_{13}$ , then subtract by  $\Delta W'_T$ ,

$$\begin{aligned}
\Delta q'_{gw}(s) &\frac{L_{13}(s + L_{15})(s + L_9L_{10})}{(s + L_{15})(s + L_9L_{10}) + L_{12}L_{13}s} \\
- \Delta W'_T(s) &\frac{(s + L_{15})(s + L_9L_{10})}{(s + L_{15})(s + L_9L_{10}) + L_{12}L_{13}s} = L_{13}\Delta q_{Dw} - \Delta W'_T = N
\end{aligned}$$

Then the block becomes

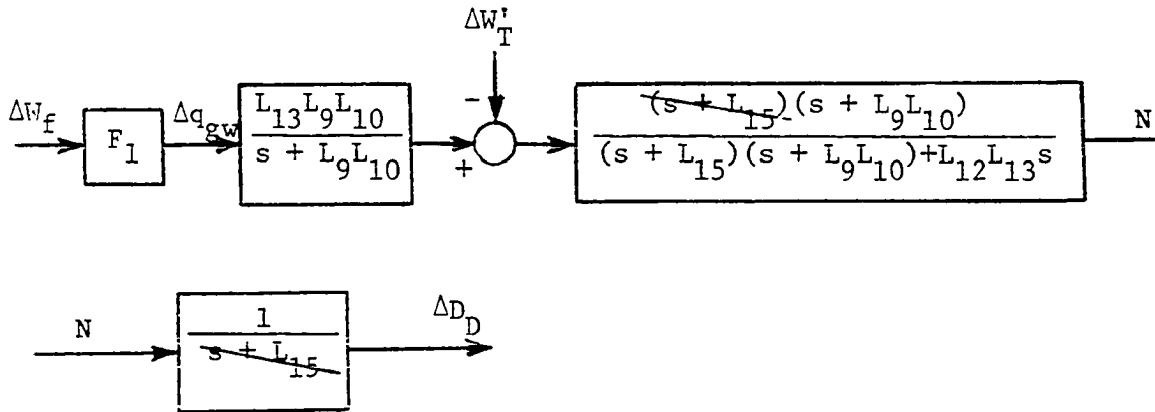

Let

$$L_9 L_{10} = P_1$$

$$F_1 L_{13} L_9 L_{10} = P_2$$

$$L_{15} + L_9 L_{10} + L_{12} L_{13} = P_3$$

$$L_{15} L_9 L_{10} = P_4$$

The original block becomes

